

WIRE TERMINATION

WIRE CONNECTORS.....	C-2
CORD-END TERMINALS.....	C-7
PUSH-IN CONNECTORS	C-13
TERMINALS	C-16
TOOLS	C-70

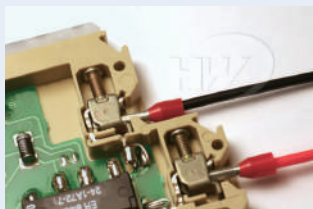

INTRODUCTION OF WIRE CONNECTORS

Hua Wei is the leader in providing a wide range of connectors suitable for the majority of all applications. In fact, the high quality, easy-to-use, versatile connectors from Hua Wei have been greatly used in different industries and different continents. Whatever the application - commercial, industrial, OEM, utility, residential, communications - and whatever the voltage - low, medium or high - we have the right connector for you.

With the full range of connectors, Hua Wei offers a complete wire connection system:

- Connectors for wire/cables from 8 through 22 AWG
- Winged, non-winged, grounding, high-temperature and close-end wire connectors
- Standard and unique products for specific applications
- Products for harsh or ambient environments
- Complete range of tools for close-end crimp connectors

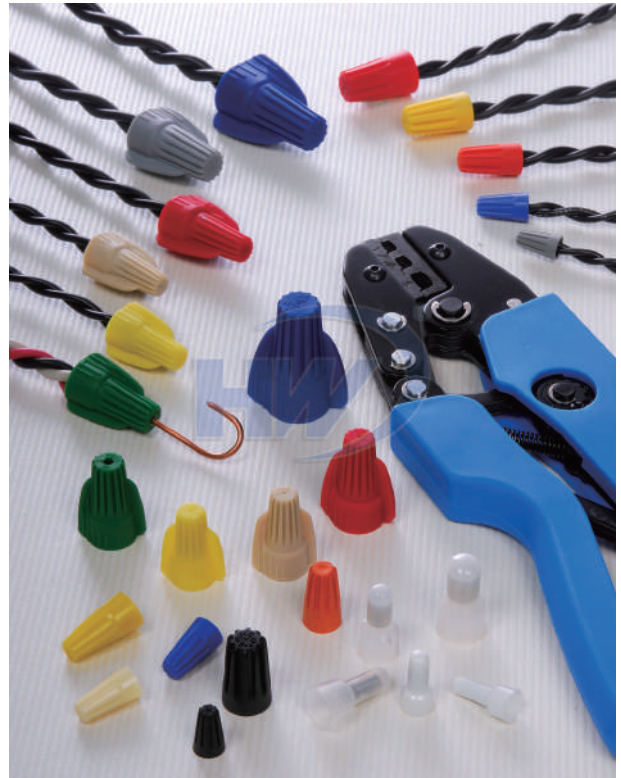

Termination Systems Capabilities

Features	Benefits
<ul style="list-style-type: none"> • Big wings with molded vertical ribs 	Provide a secure grip for more torque on maximum wire combinations
<ul style="list-style-type: none"> • Color coded shells 	Instant identification and selection of the wire connectors
<ul style="list-style-type: none"> • High conductivity square-wire spring and metal tubes 	Superior conductivity and low contact resistance with a strong connection
<ul style="list-style-type: none"> • Easy entry funnel design 	Avoid wire hang up and allows fast and secure insertion of the conductor
<ul style="list-style-type: none"> • Thermoplastic insulation materials 	Tough, UL 94-V2 flame-retardant shell rated at 105°C (221°F) Ideal for harsh environments, excellent chemical, impact and abrasion resistance
<ul style="list-style-type: none"> • Electro-tin plating 	Maximum corrosion resistance
<ul style="list-style-type: none"> • Specifications 	According to UL specifications and RoHS compliance
<ul style="list-style-type: none"> • Dedicated tooling range 	Reliable and high quality crimps, for all kind of close-end crimp connectors

W SERIES WINGED WIRE CONNECTORS

- 5 color-coded models cover a full range of wire sizes from 18 through 8 AWG
- Big wings with molded vertical ribs provide a secure grip for more torque on maximum wire combinations
- Fixed, square-wire spring maintains a strong grip that wire connections will not relax over time
- No pre-twisting required - positive grip design provides fast, easy installation
- Deep skirt helps protect against flash-over and turned-back strands for maximum dielectric protection
- Tough, UL94V-2 flame-retardant shell rated at 105°C (221°F)
- UL Listed to 486C and comply with Federal Specification W-S-610E
- Material: UL approved PP, steel spring

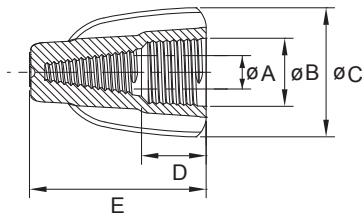

Part No.	Temp Rating	Voltage	Dimension mm (inch)					Suitable Wire AWG	Wire Strip Length mm (inch)	Color
			A	B	C	D	E			
W1	105°C (221°F)	600V	ø6.7 (0.26)	ø10.0 (0.39)	ø19.0 (0.75)	8.7 (0.34)	25.9 (1.02)	18-10	14.0 (0.55)	Yellow
W2	105°C (221°F)	600V	ø7.8 (0.31)	ø11.2 (0.44)	ø19.0 (0.75)	8.6 (0.34)	28.9 (1.14)	18-8	14.0 (0.55)	Tan
W3	105°C (221°F)	600V	ø9.4 (0.37)	ø13.3 (0.52)	ø22.9 (0.90)	9.2 (0.36)	31.9 (1.26)	18-8	12.0 (0.47)	Red
W4	105°C (221°F)	600V	ø10.5 (0.41)	ø14.5 (0.57)	ø25.1 (0.99)	9.6 (0.38)	32.8 (1.29)	18-10	14.0 (0.55)	Grey
W5	105°C (221°F)	600V	ø12.8 (0.50)	ø17.5 (0.69)	ø31.8 (1.25)	12.5 (0.49)	40.2 (1.58)	12-8	20.0 (0.79)	Blue

WINGED GROUNDING WIRE CONNECTORS

- Designed for making ground connections
- Big wings with molded vertical ribs provide a secure grip for more torque on maximum wire combinations
- Fixed, square-wire spring maintains a strong grip that wire connections will not relax over time
- Tough, UL94V-2 flame-retardant shell
- UL Listed to 467 and complies with Federal Specification W-S-610E
- Material: UL approved PP, steel spring

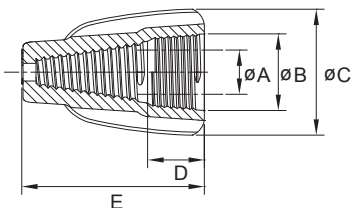

Part No.	Temp Rating	Voltage	Dimension mm (inch)					Suitable Wire AWG	Wire Strip Length mm (inch)	Color
			A	B	C	D	E			
WG	105°C (221°F)	600V	ø9.4 (0.37)	ø12.2 (0.48)	ø19.9 (0.78)	9.1 (0.36)	28.9 (1.14)	14-10	12.0 (0.47)	Green

E SERIES WIRE CONNECTORS

- Five color-coded models cover a full range of wire sizes from 22-10 AWG
- Fixed, square-wire spring maintains a strong grip that wire connections will not relax over time
- No pre-twisting required - positive grip design provides fast, easy installation
- Deep, wide skirt helps protect against flash-over and turned-back strands for maximum dielectric protection
- Tough, UL94V-2 flame-retardant shell rated at 105°C (221°F)
- UL Listed to 486C and comply with Federal Specification W-S-610E
- Material: UL approved PP, steel spring

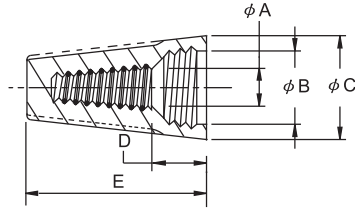

Part No.	Temp Rating	Voltage	Dimension mm (inch)					Suitable Wire AWG	Wire Strip Length mm (inch)	Color
			A	B	C	D	E			
E1	105°C (221°F)	300V	ø5.0 (0.20)	ø6.0 (0.24)	ø8.5 (0.33)	3.5 (0.14)	14.7 (0.58)	22-18	9.0 (0.35)	Grey
E2	105°C (221°F)	300V	ø6.0 (0.24)	ø7.5 (0.30)	ø10.1 (0.40)	6.5 (0.26)	17.5 (0.69)	22-14	12.0 (0.47)	Blue
E3	105°C (221°F)	600V	ø6.2 (0.24)	ø8.2 (0.32)	ø11.2 (0.44)	8.0 (0.31)	21.4 (0.84)	22-14	12.5 (0.49)	Orange
E4	105°C (221°F)	600V	ø8.7 (0.34)	ø10.5 (0.41)	ø13.7 (0.54)	7.5 (0.30)	23.6 (0.93)	18-10	13.0 (0.51)	Yellow
E6	105°C (221°F)	600V	ø9.3 (0.37)	ø13.2 (0.52)	ø16.0 (0.63)	10.1 (0.40)	26.0 (1.02)	22-10	14.0 (0.55)	Red

E SERIES HIGH TEMPERATURE WIRE CONNECTORS

- Black, thermoplastic shell designed to be used in high-wattage light fixtures and signs where the extreme heat build-up commonly found
- Four models to cover wire ranges from 22 through 10 AWG
- Material: Polyamide 6,6, heat-resistant

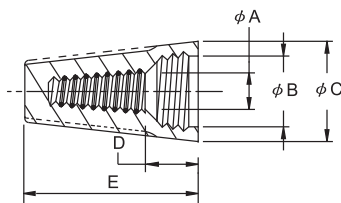

Part No.	Temp Rating	Voltage	Dimension mm (inch)					Suitable Wire AWG	Wire Strip Length mm (inch)	Color
			A	B	C	D	E			
E1B	180°C (356°F)	300V	ø5.0 (0.20)	ø6.0 (0.24)	ø8.5 (0.33)	3.5 (0.14)	14.7 (0.58)	22-18	9.0 (0.35)	Black
E2B	180°C (356°F)	300V	ø6.0 (0.24)	ø7.5 (0.30)	ø10.1 (0.40)	6.5 (0.26)	17.5 (0.69)	22-14	12.0 (0.47)	Black
E3B	180°C (356°F)	600V	ø6.2 (0.24)	ø8.2 (0.32)	ø11.2 (0.44)	8.0 (0.31)	21.4 (0.84)	22-14	12.5 (0.49)	Black
E4B	180°C (356°F)	600V	ø8.7 (0.34)	ø10.5 (0.41)	ø13.7 (0.54)	7.5 (0.30)	23.6 (0.93)	18-10	13.0 (0.51)	Black

WATERPROOF WIRE CONNECTORS

- Tough thermoplastic, UL 94V-2 flame-retardant shell for 105°F (221°C).
- Rated to 600V max.
- Screw-on wire connectors pre-filled with dielectric silicone sealant. Comply with UL standard.
- Waterproof, dustproof and corrosion proof.
- For use in dry , damp, wet, bury locations. Not for use in continual submersion applications .One time use only. Do not Reuse Connector.
- Easy to use wire connectors nuts.
- Material: Shell - Polypropylene (PP). Spring - calvanized carbon steel. Fillers - dielectric silicone sealant.

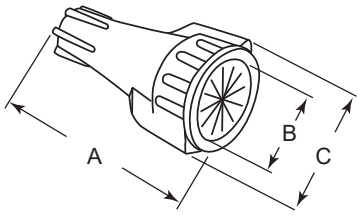

Part No.	Temp Rating	Voltage	Dimension mm (inch)			Suitable Wire AWG	Color
			A	B	C		
R3-R	105°C (221°F)	600V	40.9 (1.61)	ø16.5 (0.65)	ø25.2 (0.99)	20-10	Blue/Red
R6-R	105°C (221°F)	600V	47.2 (1.86)	ø16.5 (0.65)	ø26.5 (1.04)	20-8	Blue/Black

Applications:

- Outdoor lighting and signage
- Outdoor power outlets
- Sump and well pump installations
- Basement, garage and car-port circuits
- Bathroom/spa vent fans
- Security systems and lighting
- Irrigation systems
- Marine shore power and dock lighting
- HVAC systems



HVAC systems

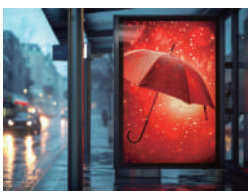

Outdoor lighting and signage



Irrigation systems



Marine shore power

Easy to Use

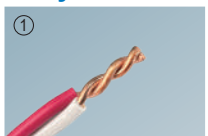

① Strip the wire with the lead for 13 ~ 16mm (0.51 ~ 0.63 inch).



② Insert the spliced wire until the wire touches the bottom of the wire connector.



③ Turn clockwise until the wire is very tight with at least 2 twists visible

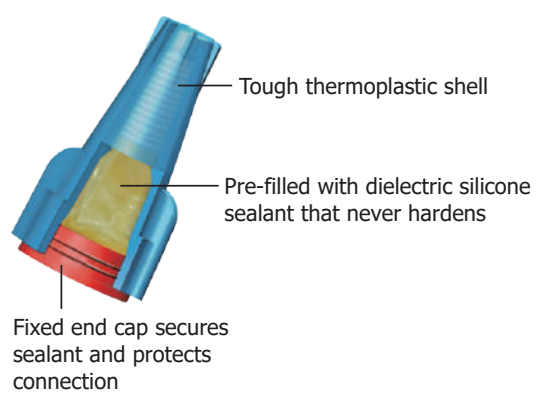

Wire Termination
Wire Connectors

C SERIES CLOSE-END CRIMP CONNECTORS

- Four models cover a wide range of wire combinations from 22 AWG strands through 10 AWG stranded
- Compact design fits easily into tight locations
- Flared skirt ensures easily wire entry and protects against turned-back strands
- UL Listed for 300V maximum building wiring; temperature rated at 105°C (221°F) maximum
- P/N with postfix V0 means the shell is UL94V-0 flame-retardant
- P/N with postfix "-L" means the tube is made of aluminum
- Material: UL approved 94V-2 Polyamide 6,6, copper tube or aluminum tube

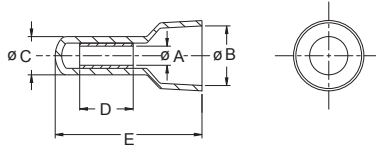

Part No.	Temp Rating	Voltage	Dimension mm (inch)					Suitable Wire AWG	Wire Strip Length mm (inch)	Color	Suitable Crimping Tools
			A	B	C	D	E				
C3	105°C (221°F)	300V	ø2.6 (0.10)	ø7.6 (0.30)	ø5.0 (0.20)	6.8 (0.27)	18.0 (0.71)	22-16	16.0 (0.63)	Natural	GIT-517C1
C4	105°C (221°F)	300V	ø3.2 (0.13)	ø7.6 (0.30)	ø5.8 (0.23)	6.8 (0.27)	20.4 (0.80)	22-14	16.0 (0.63)	Natural	
C5	105°C (221°F)	300V	ø4.3 (0.17)	ø10.3 (0.41)	ø7.0 (0.28)	7.8 (0.31)	24.8 (0.98)	22-10	20.0 (0.79)	Natural	
C8	105°C (221°F)	300V	ø5.0 (0.20)	ø12.2 (0.48)	ø9.2 (0.36)	8.8 (0.35)	27.0 (1.06)	20-10	21.0 (0.83)	Natural	GIT-517C5
C3-L	105°C (221°F)	300V	ø2.6 (0.10)	ø7.6 (0.30)	ø5.0 (0.20)	6.8 (0.27)	18.0 (0.71)	22-16	16.0 (0.63)	Natural	GIT-517C1
C4-L	105°C (221°F)	300V	ø3.2 (0.13)	ø7.6 (0.30)	ø5.8 (0.23)	6.8 (0.27)	20.4 (0.80)	22-14	16.0 (0.63)	Natural	
C5-L	105°C (221°F)	300V	ø4.3 (0.17)	ø10.3 (0.41)	ø7.0 (0.28)	7.8 (0.31)	24.8 (0.98)	22-10	20.0 (0.79)	Natural	
C3V0	105°C (221°F)	300V	ø2.6 (0.10)	ø7.6 (0.30)	ø5.0 (0.20)	6.8 (0.27)	18.0 (0.71)	22-16	16.0 (0.63)	White	
C4V0	105°C (221°F)	300V	ø3.2 (0.13)	ø7.6 (0.30)	ø5.8 (0.23)	6.8 (0.27)	20.4 (0.80)	22-14	16.0 (0.63)	White	
C5V0	105°C (221°F)	300V	ø4.3 (0.17)	ø10.3 (0.41)	ø7.0 (0.28)	7.8 (0.31)	24.8 (0.98)	22-10	20.0 (0.79)	White	
C3-LV0	105°C (221°F)	300V	ø2.6 (0.10)	ø7.6 (0.30)	ø5.0 (0.20)	6.8 (0.27)	18.0 (0.71)	22-16	16.0 (0.63)	White	
C4-LV0	105°C (221°F)	300V	ø3.2 (0.13)	ø7.6 (0.30)	ø5.8 (0.23)	6.8 (0.27)	20.4 (0.80)	22-14	16.0 (0.63)	White	
C5-LV0	105°C (221°F)	300V	ø4.3 (0.17)	ø10.3 (0.41)	ø7.0 (0.28)	7.8 (0.31)	24.8 (0.98)	22-10	20.0 (0.79)	White	

INTRODUCTION OF WIRE CONNECTORS

Features of Hua Wei's Cord-End Terminals

- Applicable for wires from 0.25 mm² to 150 mm²
- Included un-insulated, insulated single wire and insulated twin wires cord-end terminals
- Comply to related standard and satisfy all kinds of applications
- Applied to different hostile environment
- Ergonomical ratchet tools and effort-saving hydraulic pressure tools are available



Hua Wei's Cord-End Terminals Provide Most Efficient Termination Solution

Features	Benefits
• High conductivity electrolytic copper	Superior conductivity and low contact resistance with a strong connection
• Electro-tin plating	Maximum corrosion resistance
• Brazed seam	No barrel separation during crimping
• The contact area on the terminal is harder than the crimp area	Better resistance to mechanical deformations
• Easy entry funnel design	Fast and secure insertion of the conductor
• Color coded insulators according to DIN cable size	Instant identification and selection of the terminal
• PA insulation materials	+85°C / +105°C, UL94V-2 Ideal for harsh environments, excellent chemical, impact and abrasion resistance
• Size marking	Clear and easy identification of the terminal
• Specifications	All in accordance to DIN specifications
• Choice of the connector	Reliable and high quality crimps, for all kind of volumes

UN-INSULATED CORD-END TERMINALS

- Designed with a seamless barrel to contain loose wire strands for superior terminations
- Ease of inserting wire into terminal block
- Meets DIN standards for wire containment
- Suitable for limited space panel applications
- Multiple pin lengths available for a variety of terminal blocks
- Material: Copper tube with tin plated

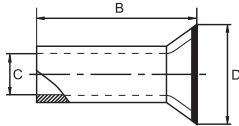

Part No.	Conductor		Dimension mm (inch)			Tools
	sq. mm.	AWG	B	C	D	
CN005006	0.50	22-20	6.0 (0.24)	1.0 (0.04)	2.1 (0.08)	GIT-510 GIT-516E1
CN005008	0.50	22-20	8.0 (0.31)	1.0 (0.04)	2.1 (0.08)	
CN005010	0.50	22-20	10.0 (0.39)	1.0 (0.04)	2.1 (0.08)	
CN007506	0.75	20-19	6.0 (0.24)	1.2 (0.05)	2.3 (0.09)	
CN007508	0.75	20-19	8.0 (0.31)	1.2 (0.05)	2.3 (0.09)	
CN007510	0.75	20-19	10.0 (0.39)	1.2 (0.05)	2.3 (0.09)	
CN010006	1.00	18	6.0 (0.24)	1.4 (0.06)	2.5 (0.10)	
CN010008	1.00	18	8.0 (0.31)	1.4 (0.06)	2.5 (0.10)	
CN010010	1.00	18	10.0 (0.39)	1.4 (0.06)	2.5 (0.10)	
CN010012	1.00	18	12.0 (0.47)	1.4 (0.06)	2.5 (0.10)	
CN015007	1.50	16	7.0 (0.28)	1.7 (0.07)	2.8 (0.11)	
CN015008	1.50	16	8.0 (0.31)	1.7 (0.07)	2.8 (0.11)	
CN015010	1.50	16	10.0 (0.39)	1.7 (0.07)	2.8 (0.11)	
CN015012	1.50	16	12.0 (0.47)	1.7 (0.07)	2.8 (0.11)	
CN025007	2.50	14	7.0 (0.28)	2.2 (0.09)	3.4 (0.13)	
CN025008	2.50	14	8.0 (0.31)	2.2 (0.09)	3.4 (0.13)	
CN025010	2.50	14	10.0 (0.39)	2.2 (0.09)	3.4 (0.13)	
CN025012	2.50	14	12.0 (0.47)	2.2 (0.09)	3.4 (0.13)	
CN025018	2.50	14	18.0 (0.71)	2.2 (0.09)	3.4 (0.13)	
CN040008	4.00	12	8.0 (0.31)	2.8 (0.11)	4.0 (0.16)	GIT-516E1
CN040009	4.00	12	9.0 (0.35)	2.8 (0.11)	4.0 (0.16)	
CN040010	4.00	12	10.0 (0.39)	2.8 (0.11)	4.0 (0.16)	
CN040012	4.00	12	12.0 (0.47)	2.8 (0.11)	4.0 (0.16)	GIT-516E1
CN040015	4.00	12	15.0 (0.59)	2.8 (0.11)	4.0 (0.16)	
CN040018	4.00	12	18.0 (0.71)	2.8 (0.11)	4.0 (0.16)	
CN060010	6.00	10	10.0 (0.39)	3.5 (0.14)	4.7 (0.19)	GIT-516E2
CN060012	6.00	10	12.0 (0.47)	3.5 (0.14)	4.7 (0.19)	
CN060015	6.00	10	15.0 (0.59)	3.5 (0.14)	4.7 (0.19)	
CN060018	6.00	10	18.0 (0.71)	3.5 (0.14)	4.7 (0.19)	

UN-INSULATED CORD-END TERMINALS

Part No.	Conductor		Dimension mm (inch)			Tools
	sq. mm.	AWG	B	C	D	
CN100012	10.00	8	12.0 (0.47)	4.5 (0.18)	5.8 (0.23)	GIT-516E2 GIT-516E3 GIT-518
CN100015	10.00	8	15.0 (0.59)	4.5 (0.18)	5.8 (0.23)	
CN100018	10.00	8	18.0 (0.71)	4.5 (0.18)	5.8 (0.23)	
CN160012	16.00	6	12.0 (0.47)	5.8 (0.23)	7.5 (0.30)	
CN160015	16.00	6	15.0 (0.59)	5.8 (0.23)	7.5 (0.30)	
CN160018	16.00	6	18.0 (0.71)	5.8 (0.23)	7.5 (0.30)	
CN250015	25.00	4	15.0 (0.59)	7.3 (0.29)	9.5 (0.37)	GIT-516E3 GIT-516E4 GIT-518
CN250016	25.00	4	16.0 (0.63)	7.3 (0.29)	9.5 (0.37)	
CN250018	25.00	4	18.0 (0.71)	7.3 (0.29)	9.5 (0.37)	
CN250020	25.00	4	20.0 (0.79)	7.3 (0.29)	9.5 (0.37)	
CN250022	25.00	4	22.0 (0.87)	7.3 (0.29)	9.5 (0.37)	
CN350016	35.00	2	16.0 (0.63)	8.3 (0.33)	11.0 (0.43)	GIT-516E4 GIT-518
CN350018	35.00	2	18.0 (0.71)	8.3 (0.33)	11.0 (0.43)	
CN350020	35.00	2	20.0 (0.79)	8.3 (0.33)	11.0 (0.43)	
CN350025	35.00	2	25.0 (0.98)	8.3 (0.33)	11.0 (0.43)	
CN500018	50.00	1/0	18.0 (0.71)	10.3 (0.41)	13.0 (0.51)	
CN500020	50.00	1/0	20.0 (0.79)	10.3 (0.41)	13.0 (0.51)	
CN500022	50.00	1/0	22.0 (0.87)	10.3 (0.41)	13.0 (0.51)	
CN500025	50.00	1/0	25.0 (0.98)	10.3 (0.41)	13.0 (0.51)	
CN700022	70.00	2/0	22.0 (0.87)	13.5 (0.53)	15.3 (0.60)	GIT-518
CN700025	70.00	2/0	25.0 (0.98)	13.5 (0.53)	15.3 (0.60)	
CN700032	70.00	2/0	32.0 (1.26)	13.5 (0.53)	15.3 (0.60)	
CN950025	95.00	3/0	25.0 (0.98)	14.7 (0.58)	16.6 (0.65)	
CN950032	95.00	3/0	32.0 (1.26)	14.7 (0.58)	16.6 (0.65)	
CN120030	120.00	4/0	30.0 (1.18)	16.7 (0.66)	18.6 (0.73)	
CN120032	120.00	4/0	32.0 (1.26)	16.7 (0.66)	18.6 (0.73)	
CN120034	120.00	4/0	34.0 (1.34)	16.7 (0.66)	18.6 (0.73)	
CN150032	150.00	250/300	32.0 (1.26)	19.5 (0.77)	21.5 (0.85)	
CN150038	150.00	250/300	38.0 (1.50)	19.5 (0.77)	21.5 (0.85)	

* DIN 46228/1

CORD-END TERMINALS

- Insulation housing conforms to DIN color requirements
- Meets DIN standards for single wire containment
- Funnel entry for faster insertion and lower installed cost
- Designed with a seamless barrel to contain loose wire strands for superior terminations
- Ease of inserting wire into terminal block
- Suitable for limited space panel applications
- Multiple pin lengths available for a variety of terminal blocks
- Material: Copper tube with tin plated end sleeves with insulation Polyamide 6,6
- Temperature range: Up to 105°C (221°F)

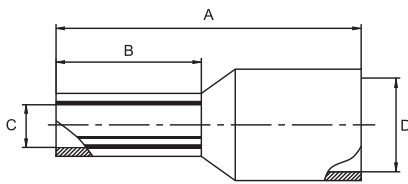

Color (1)		Color (2)		Color DIN46228/4		Conductor sq. mm. (AWG)	Dimension mm (inch)				Tools
Part No. (W system)	Part No. (T system)	Part No. (DIN system)					A	B	C	D	
CE002506W	Light Blue	CE002506T	Violet			0.25 (26-24)	10.0 (0.39)	6.0 (0.24)	0.8 (0.03)	1.9 (0.07)	GIT-510
CE002508W	Light Blue	CE002508T	Violet			0.25 (26-24)	12.0 (0.47)	8.0 (0.31)	0.8 (0.03)	1.9 (0.07)	
CE003406W	Turquoise	CE003406T	Pink			0.34 (24-22)	10.0 (0.39)	6.0 (0.24)	0.8 (0.03)	1.9 (0.07)	
CE003408W	Turquoise	CE003408T	Pink			0.34 (24-22)	12.0 (0.47)	8.0 (0.31)	0.8 (0.03)	1.9 (0.07)	
CE005006W	Orange	CE005006T	White	CE005006D	White	0.50 (22-20)	12.0 (0.47)	6.0 (0.24)	1.0 (0.04)	2.6 (0.10)	GIT-510 GIT-516E1
CE005008W	Orange	CE005008T	White	CE005008D	White	0.50 (22-20)	14.0 (0.55)	8.0 (0.31)	1.0 (0.04)	2.6 (0.10)	
CE005010W	Orange	CE005010T	White	CE005010D	White	0.50 (22-20)	16.0 (0.63)	10.0 (0.39)	1.0 (0.04)	2.6 (0.10)	
CE007506W	White	CE007506T	Light Blue	CE007506D	Grey	0.75 (20-19)	12.0 (0.47)	6.0 (0.24)	1.2 (0.05)	2.8 (0.11)	
CE007508W	White	CE007508T	Light Blue	CE007508D	Grey	0.75 (20-19)	14.0 (0.55)	8.0 (0.31)	1.2 (0.05)	2.8 (0.11)	
CE007510W	White	CE007510T	Light Blue	CE007510D	Grey	0.75 (20-19)	16.0 (0.63)	10.0 (0.39)	1.2 (0.05)	2.8 (0.11)	
CE007512W	White	CE007512T	Light Blue	CE007512D	Grey	0.75 (20-19)	18.0 (0.71)	12.0 (0.47)	1.2 (0.05)	2.8 (0.11)	
CE010006W	Yellow	CE010006T	Red	CE010006D	Red	1.00 (18)	12.0 (0.47)	6.0 (0.24)	1.4 (0.06)	3.0 (0.12)	
CE010008W	Yellow	CE010008T	Red	CE010008D	Red	1.00 (18)	14.0 (0.55)	8.0 (0.31)	1.4 (0.06)	3.0 (0.12)	
CE010010W	Yellow	CE010010T	Red	CE010010D	Red	1.00 (18)	16.0 (0.63)	10.0 (0.39)	1.4 (0.06)	3.0 (0.12)	
CE010012W	Yellow	CE010012T	Red	CE010012D	Red	1.00 (18)	18.0 (0.71)	12.0 (0.47)	1.4 (0.06)	3.0 (0.12)	
CE015008W	Red	CE015008T	Black	CE015008D	Black	1.50 (16)	14.0 (0.55)	8.0 (0.31)	1.7 (0.07)	3.5 (0.14)	
CE015010W	Red	CE015010T	Black	CE015010D	Black	1.50 (16)	16.0 (0.63)	10.0 (0.39)	1.7 (0.07)	3.5 (0.14)	
CE015012W	Red	CE015012T	Black	CE015012D	Black	1.50 (16)	18.0 (0.71)	12.0 (0.47)	1.7 (0.07)	3.5 (0.14)	
CE015018W	Red	CE015018T	Black	CE015018D	Black	1.50 (16)	24.0 (0.94)	18.0 (0.71)	1.7 (0.07)	3.5 (0.14)	

CORD-END TERMINALS

Color (1)		Color (2)		Color DIN46228/4		Conductor sq. mm. (AWG)	Dimension mm (inch)				Tools
Part No. (W system)		Part No. (T system)		Part No. (DIN system)			A	B	C	D	
CE025008W	Blue	CE025008T	Grey	CE025008D	Blue	2.50 (14)	14.0 (0.55)	8.0 (0.31)	2.2 (0.09)	4.2 (0.17)	GIT-510 GIT-516E1
CE025010W	Blue	CE025010T	Grey	CE025010D	Blue	2.50 (14)	16.0 (0.63)	10.0 (0.39)	2.2 (0.09)	4.2 (0.17)	
CE025012W	Blue	CE025012T	Grey	CE025012D	Blue	2.50 (14)	18.0 (0.71)	12.0 (0.47)	2.2 (0.09)	4.2 (0.17)	
CE025018W	Blue	CE025018T	Grey	CE025018D	Blue	2.50 (14)	24.0 (0.94)	18.0 (0.71)	2.2 (0.09)	4.2 (0.17)	
CE040010W	Grey	CE040010T	Orange	CE040010D	Grey	4.00 (12)	17.0 (0.67)	10.0 (0.39)	2.8 (0.11)	4.8 (0.19)	GIT-516E1
CE040012W	Grey	CE040012T	Orange	CE040012D	Grey	4.00 (12)	20.0 (0.79)	12.0 (0.47)	2.8 (0.11)	4.8 (0.19)	
CE040018W	Grey	CE040018T	Orange	CE040018D	Grey	4.00 (12)	26.0 (1.02)	18.0 (0.71)	2.8 (0.11)	4.8 (0.19)	
CE060012W	Black	CE060012T	Green	CE060012D	Yellow	6.00 (10)	20.0 (0.79)	12.0 (0.47)	3.5 (0.14)	6.3 (0.25)	GIT-516E2
CE060018W	Black	CE060018T	Green	CE060018D	Yellow	6.00 (10)	26.0 (1.02)	18.0 (0.71)	3.5 (0.14)	6.3 (0.25)	
CE100012W	Ivory	CE100012T	Brown	CE100012D	Red	10.00 (8)	22.0 (0.87)	12.0 (0.47)	4.5 (0.18)	7.6 (0.30)	GIT-516E2 GIT-516E3 GIT-518
CE100018W	Ivory	CE100018T	Brown	CE100018D	Red	10.00 (8)	28.0 (1.10)	18.0 (0.71)	4.5 (0.18)	7.6 (0.30)	
CE160012W	Green	CE160012T	Ivory	CE160012D	Blue	16.00 (6)	22.0 (0.87)	12.0 (0.47)	5.8 (0.23)	8.8 (0.35)	GIT-516E3 GIT-518
CE160018W	Green	CE160018T	Ivory	CE160018D	Blue	16.00 (6)	28.0 (1.10)	18.0 (0.71)	5.8 (0.23)	8.8 (0.35)	
CE250016W	Brown	CE250016T	Black	CE250016D	Yellow	25.00 (4)	30.0 (1.18)	16.0 (0.63)	7.3 (0.29)	11.2 (0.44)	GIT-516E3
CE250018W	Brown	CE250018T	Black	CE250018D	Yellow	25.00 (4)	32.0 (1.26)	18.0 (0.71)	7.3 (0.29)	11.2 (0.44)	GIT-516E4
CE250022W	Brown	CE250022T	Black	CE250022D	Yellow	25.00 (4)	36.0 (1.42)	22.0 (0.87)	7.3 (0.29)	11.2 (0.44)	GIT-518
CE350016W	Beige	CE350016T	Red	CE350016D	Red	35.00 (2)	30.0 (1.18)	16.0 (0.63)	8.3 (0.33)	12.7 (0.50)	GIT-516E4 GIT-518
CE350018W	Beige	CE350018T	Red	CE350018D	Red	35.00 (2)	32.0 (1.26)	18.0 (0.71)	8.3 (0.33)	12.7 (0.50)	
CE350025W	Beige	CE350025T	Red	CE350025D	Red	35.00 (2)	39.0 (1.54)	25.0 (0.98)	8.3 (0.33)	12.7 (0.50)	
CE500020W	Olive	CE500020T	Blue	CE500020D	Blue	50.00 (1/0)	36.0 (1.42)	20.0 (0.79)	10.3 (0.41)	15.0 (0.59)	GIT-518
CE500025W	Olive	CE500025T	Blue	CE500025D	Blue	50.00 (1/0)	40.0 (1.57)	25.0 (0.98)	10.3 (0.41)	15.0 (0.59)	
CE700021W	Yellow	CE700021T	Yellow	CE700021D	Yellow	70.00 (2/0)	37.0 (1.46)	21.0 (0.83)	13.5 (0.53)	16.0 (0.63)	GIT-518
CE950025W	Red	CE950025T	Red	CE950025D	Red	95.00 (3/0)	44.0 (1.73)	25.0 (0.98)	14.7 (0.58)	18.0 (0.71)	
CE120027W	Blue	CE120027T	Blue	CE120027D	Blue	120.00 (4/0)	48.0 (1.89)	27.0 (1.06)	16.7 (0.66)	20.0 (0.79)	
CE150032W	Yellow	CE150032T	Yellow	CE150032D	Yellow	150.00 (250/300)	58.0 (2.28)	32.0 (1.26)	19.5 (0.77)	23.0 (0.91)	

* DIN 46228/4

TWIN CORD-END TERMINALS

- Meets DIN standards for twin wire containment
- Insulation housing conforms to DIN color requirements
- Funnel entry for faster insertion and lower installed cost
- Designed with a seamless barrel to contain loose wire strands for superior terminations
- Ease of inserting wire into terminal block
- Suitable for limited space panel applications
- Multiple pin lengths available for a variety of terminal blocks
- Material: Copper tube with tin plated end sleeves with insulation Polyamide 6,6
- Temperature range: Up to 105°C (221°F)

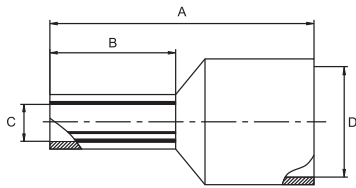

Color (1)		Color (2)		Color DIN46228/4		Conductor sq. mm. (AWG)	Dimension mm (inch)				Tools
Part No. (W system)		Part No. (T system)		Part No. (DIN system)			A	B	C	D	
CT205008W	Orange	CT205008T	White	CT205008D	White	2x0.50 (2x22-20)	15.0 (0.59)	8.0 (0.31)	1.5 (0.06)	4.7 (0.19)	GIT-510 GIT-516E1
CT207508W	White	CT207508T	Blue	CT207508D	Grey	2x0.75 (2x20-19)	15.0 (0.59)	8.0 (0.31)	1.8 (0.07)	5.0 (0.20)	
CT207510W	White	CT207510T	Blue	CT207510D	Grey	2x0.75 (2x20-19)	17.0 (0.67)	10.0 (0.39)	1.8 (0.07)	5.0 (0.20)	
CT210008W	Yellow	CT210008T	Red	CT210008D	Red	2x1.00 (2x18)	15.0 (0.59)	8.0 (0.31)	2.1 (0.08)	5.4 (0.21)	
CT210010W	Yellow	CT210010T	Red	CT210010D	Red	2x1.00 (2x18)	17.0 (0.67)	10.0 (0.39)	2.1 (0.08)	5.4 (0.21)	
CT215008W	Red	CT215008T	Black	CT215008D	Black	2x1.50 (2x16)	16.0 (0.63)	8.0 (0.31)	2.3 (0.09)	6.6 (0.26)	
CT215012W	Red	CT215012T	Black	CT215012D	Black	2x1.50 (2x16)	20.0 (0.79)	12.0 (0.47)	2.3 (0.09)	6.6 (0.26)	
CT225010W	Blue	CT225010T	Grey	CT225010D	Blue	2x2.50 (2x14)	18.5 (0.73)	10.0 (0.39)	2.8 (0.11)	7.8 (0.31)	GIT-516E1
CT225013W	Blue	CT225013T	Grey	CT225013D	Blue	2x2.50 (2x14)	21.5 (0.85)	13.0 (0.51)	2.8 (0.11)	7.8 (0.31)	
CT240012W	Grey	CT240012T	Orange	CT240012D	Grey	2x4.00 (2x12)	23.0 (0.91)	12.0 (0.47)	3.7 (0.15)	8.8 (0.35)	GIT-516E2
CT260014W	Black	CT260014T	Green	CT260014D	Yellow	2x6.00 (2x10)	26.0 (1.02)	14.0 (0.55)	4.8 (0.19)	10.0 (0.39)	GIT-516E2 GIT-516E3 GIT-518
CT210014W	Ivory	CT210014T	Brown	CT210014D	Red	2x10.00 (2x8)	26.5 (1.04)	14.0 (0.55)	6.4 (0.25)	12.8 (0.50)	
CT216014W	Green	CT216014T	Ivory	CT216014D	Blue	2x16.00 (2x6)	31.5 (1.24)	14.0 (0.55)	8.3 (0.33)	18.6 (0.73)	GIT-516E3 GIT-516E4 GIT-518

* DIN 46228/4

INTRODUCTION OF PUSH-IN CONNECTORS



Hua Wei's push-in connectors are designed for various wire types – solid, stranded, and flexible – from 28 to 10 AWG, offering the perfect fit for every wiring need. With color-coded precision, identifying connections is a walk in the park, while the compact size ensures a seamless fit into tight spaces. Ideal for various applications, including lighting installations, pre-fabricated wiring systems, and branch circuit wiring.

Say goodbye to complicated twisting – push your way to rapid, reliable connections with our compact and clear choice push-in connectors. Your go-to solution for any splicing job, Hua Wei's push-in connectors redefine convenience in electrical installations.







Comply with the standard UL 486C.

Choose Efficiency
Choose Reliability
Choose Hua Wei's Push-in Connectors

Hua Wei Series Products are Complete and Feature Exceptional Qualities:

- The **PIC21 series** is the smallest and lightest on the market, suitable for use in narrow junction boxes.
- The **PIC33 series** is ergonomically designed, performing better on stranded wires.
- The **PIC35 series** uses double spring clips, ensuring greater safety and reliability.
- The **PIC86 series** is suitable for large wire diameters.
- The **PIL62 series** is compatible with both solid and flexible wires, including single-core, stranded, and fine-stranded wires. It provides a full alternative to traditional soldering and insulated tape methods. Wires can be easily removed and reused by simply lifting the lever, saving both time and effort while also being cost-effective.

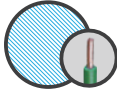
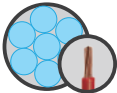
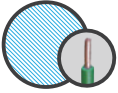
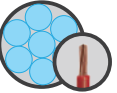
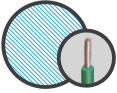
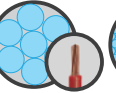
Wire Termination
Push-in Connectors

<p>Connector Type</p>	   <p>PIC21 series PIC33 series PIC35 series</p>	 <p>PIC86 series</p>	 <p>PIL62 series</p>
<p>Wire Type</p>	  <p>Solid Wire 22-12AWG Stranded Wire 22-14AWG</p>	  <p>Solid Wire 22-12AWG Stranded Wire 22-14AWG</p>	   <p>Solid Wire 22-12AWG Stranded Wire 22-14AWG Flexible Wire 28-14AWG</p>

PUSH-IN CONNECTORS

- Tool-free! No-Twist! Poke-in Wire Save Installation Time
- Simplified Design and Compact Size Helps in Tight Locations
- Check Port Design Provides Continuity Testing
- Secure Connection, Minimizing Unintentional Disconnection, and Restricting Pullouts
- Operating Temperature: 105°C / 221°F(UL) T85°C / 185°F (IEC/EN)
- HOUSING MATERIAL:
 PIC21 Series: Polycarbonate (PC), UL 94V-0
 PIC33 Series: Polycarbonate (PC), Polypropylene (PP), UL 94V-2
 PIC35 Series: Polycarbonate (PC), UL 94V-0
 PIC86 Series: Polycarbonate (PC), Polyamide (PA), UL 94V-2

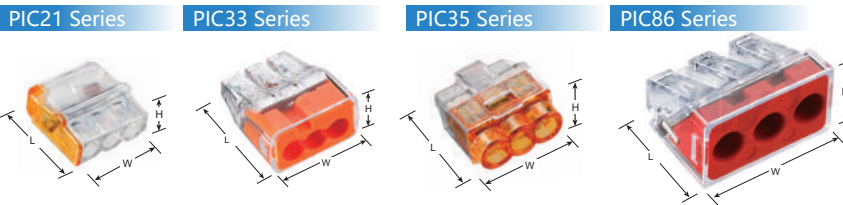

Part No.	Length (L) mm (inch)	Width (W) mm (inch)	Height (H) mm (inch)	Rated Voltage(V)		Rated Current(A) IEC/EN	Solid Conductor Wire Range		Stranded Conductor Wire Range		Ports	Color
				UL	IEC/EN		mm ²	AWG	mm ²	AWG		
PIC21 Series												
PIC21-2	16.0 (0.63)	10.5 (0.41)	7.5 (0.30)	600	450	24	0.5-2.5	22-12	0.5-2.5	22-14	2	Red
PIC21-3	16.0 (0.63)	15.0 (0.59)	7.5 (0.30)	600	450	24					3	Orange
PIC21-4	16.0 (0.63)	19.4 (0.76)	7.5 (0.30)	600	450	24					4	Yellow
PIC21-5	16.0 (0.63)	23.7 (0.93)	7.5 (0.30)	600	450	24					5	Grey
PIC21-6	16.0 (0.63)	28.2 (1.11)	7.5 (0.30)	600	450	24					6	Purple
PIC21-12	15.8 (0.62)	25.6 (1.01)	12.6 (0.50)	NA	450	24					12	Blue
PIC33 Series												
PIC33-2	18.5 (0.73)	11.1 (0.44)	9.4 (0.37)	600	450	24	0.5-4.0	22-12	0.5-2.5	22-14	2	Red
PIC33-3	18.5 (0.73)	15.5 (0.61)	9.4 (0.37)	600	450	24					3	Orange
PIC33-4	18.5 (0.73)	19.9 (0.78)	9.4 (0.37)	600	450	24					4	Yellow
PIC33-5	18.5 (0.73)	24.3 (0.96)	9.4 (0.37)	600	450	24					5	Blue
PIC35 Series												
PIC35-2	16.5 (0.65)	10.8 (0.43)	7.7 (0.30)	600	450	24	0.5-2.5	22-12	1.0-2.5	22-14	2	Yellow
PIC35-3	16.5 (0.65)	15.1 (0.59)	7.7 (0.30)	600	450	24					3	Orange
PIC35-4	16.5 (0.65)	19.4 (0.76)	7.7 (0.30)	600	450	24					4	Transparent
PIC35-5	16.5 (0.65)	23.7 (0.93)	7.7 (0.30)	600	450	24					5	Blue
PIC35-6	16.5 (0.65)	28.0 (1.10)	7.7 (0.30)	600	450	24					6	Purple
PIC35-8	16.5 (0.65)	36.6 (1.44)	7.7 (0.30)	600	450	24					8	Black
PIC86 Series												
PIC86-3	20.1 (0.79)	25.5 (1.00)	14.2 (0.56)	600	450	41	2.5-6.0	16-10	2.5-6.0	12-10	3	Red

Easy to Use:



STRIP » PUSH » CONNECT

APPLICATIONS:

- For Grounding and Bonding Applications. Use in Building, Appliance, Lighting Wiring and Junction Boxes

PUSH-IN LEVER CONNECTORS

- Tool-Free! No-Twist! Solder-Free! Time-Saving!
- Check Port Design Provides Continuity Testing
- Secure Connection, Minimizing Unintentional Disconnection, and Restricting Pullouts
- The PIL62 series is compatible with both solid and flexible wires, including single-core, stranded, and fine-stranded wires. It provides a full alternative to traditional soldering and insulated tape methods.
- Wires can be easily removed and reused by simply lifting the lever, saving both time and effort while also being cost-effective.
- Operating Temperature: 105°C / 221°F(UL) T85°C / 185°F (IEC/EN)
- HOUSING MATERIAL: PPolycarbonate (PC), Polyamide (PA), UL 94V-0

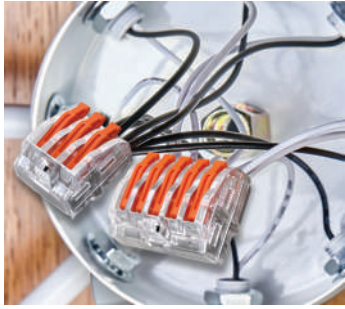

Part No.	Length (L) mm (inch)	Width (W) mm (inch)	Height (H) mm (inch)	Rated Voltage(V)		Rated Current(A)	Solid Conductor Wire Range		Stranded Conductor Wire Range		Fine-stranded Conductor Wire Range		Ports	Color
				UL	IEC/EN		IEC/EN	mm ²	AWG	mm ²	AWG	mm ²		
PIL62 Series														
PIL62-2	20.7 (0.81)	12.2 (0.48)	14.5 (0.57)	600	450	32							2	Transparent, Orange
PIL62-3	20.7 (0.81)	16.8 (0.66)	14.5 (0.57)	600	450	32	0.2-4.0	28-12	0.2-4.0	28-14	0.2-4.0	28-14	3	
PIL62-5	20.7 (0.81)	26.0 (1.02)	14.5 (0.57)	600	450	32							5	

Easy to Use:



STRIP » LIFT » INSERT » PRESS » REMOVE

APPLICATIONS:

- For Grounding and Bonding Applications. Use in Building, Appliance, Lighting Wiring and Junction Boxes



Lighting Industry



Furniture and Design Industry / Residential Junction Box Industry



Commercial Maintenance Applications



HVAC Industry

Wire Termination Push-in Connectors

NON-INSULATED RING TERMINALS

- Brazed seam protects terminal barrel from splitting during the crimping process
- Material: Copper

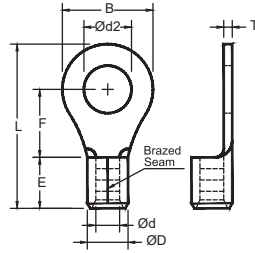

Part No.	Wire Range		Dimension mm (inch)								Stud Size	
	sq. mm.	AWG	B	Ød2	L	F	E	Ød	ØD	T	mm	inch
R1-3B	0.5-1.5	22-16	5.5 (0.22)	3.2 (0.13)	12.5 (0.49)	4.8 (0.19)	5.0 (0.20)	1.7 (0.07)	3.4 (0.13)	0.75 (0.03)	M3	#4
R1-3.5B			5.5 (0.22)	3.7 (0.15)	12.5 (0.49)	4.8 (0.19)					M3.5	#6
R1-4B			8.0 (0.31)	4.3 (0.17)	16.0 (0.63)	7.0 (0.28)					M4	#8
R1-5B			8.0 (0.31)	5.3 (0.21)	16.0 (0.63)	7.0 (0.28)					M5	#10
R1-6B			11.6 (0.46)	6.4 (0.25)	21.9 (0.86)	11.1 (0.44)					M6	1/4
R1-8B			11.6 (0.46)	8.4 (0.33)	21.9 (0.86)	11.1 (0.44)					M8	5/16
R1-10B			13.6 (0.54)	10.5 (0.41)	25.7 (1.01)	13.9 (0.55)					M10	3/8
R1-12B			19.0 (0.75)	13.0 (0.51)	30.5 (1.2)	16.0 (0.63)					M12	1/2
R2-3B	1.5	16-14	6.6 (0.26)	3.2 (0.13)	12.6 (0.5)	4.3 (0.17)	5.0 (0.20)	2.3 (0.09)	4.1 (0.16)	0.8 (0.03)	M3	#4
R2-3.5B			6.6 (0.26)	3.7 (0.15)	12.6 (0.5)	4.3 (0.17)					M3.5	#6
R2-4B			8.5 (0.33)	4.3 (0.17)	17.0 (0.67)	7.8 (0.31)					M4	#8
R2-5B			9.5 (0.37)	5.3 (0.21)	17.0 (0.67)	7.3 (0.29)					M5	#10
R2-6B			12.0 (0.47)	6.4 (0.25)	22.0 (0.87)	11.0 (0.43)					M6	1/4
R2-8B			12.0 (0.47)	8.4 (0.33)	22.0 (0.87)	11.0 (0.43)					M8	5/16
R2-10B			13.6 (0.54)	10.5 (0.41)	25.7 (1.01)	13.9 (0.55)					M10	3/8
R2-12B			19.0 (0.75)	13.0 (0.51)	30.5 (1.2)	16.0 (0.63)					M12	1/2
R3-4B	2.5-4	14-12	8.0 (0.31)	4.3 (0.17)	17.8 (0.7)	7.8 (0.31)	6.0 (0.24)	2.9 (0.11)	5.1 (0.20)	1.0 (0.04)	M4	#8
R3-5B			8.0 (0.31)	5.3 (0.21)	17.8 (0.7)	7.8 (0.31)					M5	#10
R5-3.5B	4-6	12-10	7.2 (0.28)	3.7 (0.15)	15.5 (0.61)	5.9 (0.23)	6.0 (0.24)	3.4 (0.13)	5.6 (0.22)	1.0 (0.04)	M3.5	#6
R5-4B			9.5 (0.37)	4.3 (0.17)	19.0 (0.75)	8.3 (0.33)					M4	#8
R5-5B			9.5 (0.37)	5.3 (0.21)	19.0 (0.75)	8.3 (0.33)					M5	#10
R5-6B			12.0 (0.47)	6.4 (0.25)	22.5 (0.89)	10.5 (0.41)					M6	1/4
R5-8B			15.0 (0.59)	8.4 (0.33)	27.2 (1.07)	13.7 (0.54)					M8	5/16
R5-10B			15.0 (0.59)	10.5 (0.41)	27.2 (1.07)	13.7 (0.54)					M10	3/8
R5-12B			19.2 (0.76)	13.0 (0.51)	31.6 (1.24)	16.0 (0.63)					M12	1/2

NON-INSULATED RING TERMINALS

- Brazed seam protects terminal barrel from splitting during the crimping process
- Material: Copper

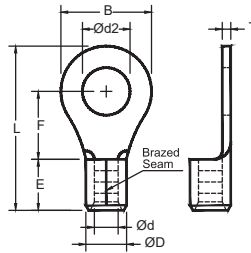

Part No.	Wire Range		Dimension mm (inch)								Stud Size	
	sq. mm.	AWG	B	Ød2	L	F	E	Ød	ØD	T	mm	inch
R8-4B	8	8	12.0 (0.47)	4.3 (0.17)	23.8 (0.94)	9.3 (0.37)	8.5 (0.33)	4.5 (0.18)	7.1 (0.28)	1.2 (0.05)	M4	#8
R8-5B			12.0 (0.47)	5.3 (0.21)	23.8 (0.94)	9.3 (0.37)					M5	#10
R8-6B			12.0 (0.47)	6.4 (0.25)	23.8 (0.94)	9.3 (0.37)					M6	1/4
R8-8B			15.0 (0.59)	8.4 (0.33)	29.8 (1.17)	13.8 (0.54)					M8	5/16
R8-10B			15.0 (0.59)	10.5 (0.41)	29.8 (1.17)	13.8 (0.54)					M10	3/8
R8-12B			20.0 (0.79)	13.0 (0.51)	33.5 (1.32)	15.0 (0.59)					M12	1/2
R14-10B	14	6	16.0 (0.63)	10.5 (0.41)	33.0 (1.3)	14.5 (0.57)	10.5 (0.41)	5.8 (0.23)	9.0 (0.35)	1.5 (0.06)	M10	3/8
R14-12B			22.0 (0.87)	13.0 (0.51)	41.0 (1.61)	19.5 (0.77)					M12	1/2
R22-5B	22	4	12.0 (0.47)	5.3 (0.21)	30.0 (1.18)	12.0 (0.47)	12.0 (0.47)	7.7 (0.30)	11.5 (0.45)	1.8 (0.07)	M5	#10
R22-6B			16.5 (0.65)	6.4 (0.25)	33.7 (1.33)	13.5 (0.53)					M6	1/4
R22-8B			16.5 (0.65)	8.4 (0.33)	33.7 (1.33)	13.5 (0.53)					M8	5/16
R22-10B			17.5 (0.69)	10.5 (0.41)	36.7 (1.44)	16.0 (0.63)					M10	3/8
R22-12B			22.0 (0.87)	13.0 (0.51)	42.5 (1.67)	19.5 (0.77)					M12	1/2
R38-6B	38	2	22.0 (0.87)	6.4 (0.25)	42.7 (1.68)	17.7 (0.7)	14.0 (0.55)	9.4 (0.37)	13.3 (0.52)	1.8 (0.07)	M6	1/4
R38-8B			22.0 (0.87)	8.4 (0.33)	42.7 (1.68)	17.7 (0.7)					M8	5/16
R38-10B			22.0 (0.87)	10.5 (0.41)	42.7 (1.68)	17.7 (0.7)					M10	3/8
R38-12B			22.0 (0.87)	13.0 (0.51)	42.7 (1.68)	17.7 (0.7)					M12	1/2

GOLD PLATED NON INSULATED RING TERMINALS (BRAZED SEAM)

- Brazed seam protects terminal barrel from splitting during the crimping process
- Ring tongue design assures a secure connection in high vibration applications
- It has excellent electrical conductivity, strong corrosion resistance and oxidation resistance, and good stability
- Material: Copper with gold plating
- Terminals Soft Sleeves for Extra Quote

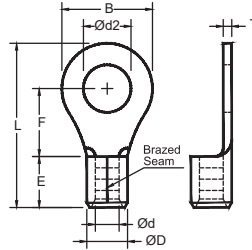

Part No.	Wire Range		Dimension mm (inch)								Stud Size	
	sq. mm.	AWG	B	Ød2	L	F	E	Ød	ØD	T	mm	inch
GR1-3B	0.5-1.5	22-16	5.5 (0.22)	3.2 (0.13)	12.5 (0.49)	4.8 (0.19)	5.0 (0.2)	1.7 (0.07)	3.4 (0.13)	0.75 (0.03)	M3	#4
GR1-3.5B			6.6 (0.26)	3.7 (0.15)	14.6 (0.57)	6.3 (0.25)					M3.5	#6
GR1-4B			8.0 (0.31)	4.3 (0.17)	16.0 (0.63)	7.0 (0.28)					M4	#8
GR1-5B			8.0 (0.31)	5.3 (0.21)	16.0 (0.63)	7.0 (0.28)					M5	#10
GR1-6B			11.6 (0.46)	6.4 (0.25)	21.9 (0.86)	11.1 (0.44)					M6	1/4
GR1-8B			11.6 (0.46)	8.4 (0.33)	21.9 (0.86)	11.1 (0.44)					M8	5/16
GR1-10B			13.6 (0.54)	10.5 (0.41)	25.7 (1.01)	13.9 (0.55)					M10	3/8
GR1-12B			19 (0.75)	13.0 (0.51)	30.5 (1.20)	16.0 (0.63)					M12	1/2
GR2-3B	1.5-2.5	16-14	6.6 (0.26)	3.2 (0.13)	12.6 (0.50)	4.3 (0.17)	5.0 (0.2)	2.3 (0.09)	4.1 (0.16)	0.8 (0.03)	M3	#4
GR2-3.5B			6.6 (0.26)	3.7 (0.15)	14.6 (0.57)	6.3 (0.25)					M3.5	#6
GR2-4B			8.5 (0.33)	4.3 (0.17)	17.0 (0.67)	7.8 (0.31)					M4	#8
GR2-5B			9.5 (0.37)	5.3 (0.21)	17.0 (0.67)	7.3 (0.29)					M5	#10
GR2-6B			12.0 (0.47)	6.4 (0.25)	22.0 (0.87)	11.0 (0.43)					M6	1/4
GR2-8B			12.0 (0.47)	8.4 (0.33)	22.0 (0.87)	11.0 (0.43)					M8	5/16
GR2-10B			13.6 (0.54)	10.5 (0.41)	25.7 (1.01)	13.9 (0.55)					M10	3/8
GR2-12B			19 (0.75)	13.0 (0.51)	30.5 (1.20)	16.0 (0.63)					M12	1/2
GR3-4B	2.5-4	14-12	8.0 (0.31)	4.3 (0.17)	17.8 (0.7)	7.8 (0.31)	6.0 (0.24)	2.9 (0.11)	5.1 (0.2)	1.0 (0.04)	M4	#8
GR3-5B			8.0 (0.31)	5.3 (0.21)	17.8 (0.7)	7.8 (0.31)					M5	#10
GR3-6B			12.0 (0.47)	6.4 (0.25)	21.4 (0.84)	9.4 (0.37)					M6	1/4
GR3-8B			15.0 (0.59)	8.4 (0.33)	26.8 (1.06)	13.3 (0.52)					M8	5/16
GR3-10B			15.0 (0.59)	10.5 (0.41)	26.8 (1.06)	13.3 (0.52)					M10	3/8
GR3-12B			19.2 (0.76)	13.0 (0.51)	31.6 (1.24)	16.0 (0.63)					M12	1/2

Wire Termination Terminals

VINYL-INSULATED RING TERMINALS

- Insulation support helps to prevent wire damage in bending applications
- Copper tube with tin plated end sleeves with insulation PVC

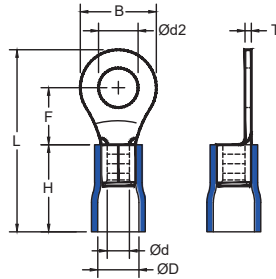

Part No.	Color	Wire Range		Dimension mm (inch)								Stud Size	
		sq. mm.	AWG	B	Ød2	L	F	H	Ød	ØD	T	mm	inch
VR1-3	Red	0.5-1.5	22-16	5.5 (0.22)	3.2 (0.13)	17.5 (0.69)	4.8 (0.19)	10.0 (0.39)	1.7 (0.07)	4.2 (0.17)	0.75 (0.03)	M3	#4
VR1-3.5				5.5 (0.22)	3.7 (0.15)	17.5 (0.69)	4.8 (0.19)					M3.5	#6
VR1-4				8.0 (0.31)	4.3 (0.17)	21.0 (0.83)	7.0 (0.28)					M4	#8
VR1-5				8.0 (0.31)	5.3 (0.21)	21.0 (0.83)	7.0 (0.28)					M5	#10
VR1-6				11.6 (0.46)	6.4 (0.25)	26.9 (1.06)	11.1 (0.44)					M6	1/4
VR1-8				11.6 (0.46)	8.4 (0.33)	26.9 (1.06)	11.1 (0.44)					M8	5/16
VR1-10				13.6 (0.54)	10.5 (0.41)	30.7 (1.21)	13.9 (0.55)					M10	3/8
VR1-12				19.0 (0.75)	13.0 (0.51)	35.6 (1.4)	16.0 (0.63)					M12	1/2
VR2-3	Blue	1.5-2.5	16-14	6.6 (0.26)	3.2 (0.13)	17.6 (0.69)	4.3 (0.17)	10.0 (0.39)	2.3 (0.09)	4.6 (0.18)	0.8 (0.03)	M3	#4
VR2-3.5				6.6 (0.26)	3.7 (0.15)	19.6 (0.77)	6.3 (0.25)					M3.5	#6
VR2-4				8.5 (0.33)	4.3 (0.17)	22 (0.87).0	7.8 (0.31)					M4	#8
VR2-5				9.5 (0.37)	5.3 (0.21)	22.0 (0.87)	7.3 (0.29)					M5	#10
VR2-6				12.0 (0.47)	6.4 (0.25)	27.0 (1.06)	11.0 (0.43)					M6	1/4
VR2-8				12.0 (0.47)	8.4 (0.33)	27.0 (1.06)	11.0 (0.43)					M8	5/16
VR2-10				13.6 (0.54)	10.5 (0.41)	30.7 (1.21)	13.9 (0.55)					M10	3/8
VR2-12				19.0 (0.75)	13.0 (0.51)	35.6 (1.4)	16.0 (0.63)					M12	1/2
VR5-3.5	Yellow	4-6	12-10	7.2 (0.28)	3.7 (0.15)	22.5 (0.89)	5.9 (0.23)	13.0 (0.51)	3.4 (0.13)	6.6 (0.26)	1.0 (0.04)	M3.5	#6
VR5-4				9.5 (0.37)	4.3 (0.17)	26.0 (1.02)	8.3 (0.33)					M4	#8
VR5-5				9.5 (0.37)	5.3 (0.21)	26.0 (1.02)	8.3 (0.33)					M5	#10
VR5-6				12.0 (0.47)	6.4 (0.25)	29.5 (1.16)	10.5 (0.41)					M6	1/4
VR5-8				15.0 (0.59)	8.4 (0.33)	34.2 (1.35)	13.7 (0.54)					M8	5/16
VR5-10				15.0 (0.59)	10.5 (0.41)	34.2 (1.35)	13.7 (0.54)					M10	3/8
VR5-12				19.2 (0.76)	13.0 (0.51)	38.6 (1.52)	16.0 (0.63)					M12	1/2

VINYL-INSULATED RING TERMINALS (EASY-ENTRY)

- Ring tongue design assures a secure connection in high vibration applications
- Insulation support helps to prevent wire damage in bending applications
- The design of the easy-entry terminal makes the installation process easier
- Material: Copper tube with tin plated end sleeves with insulation PVC

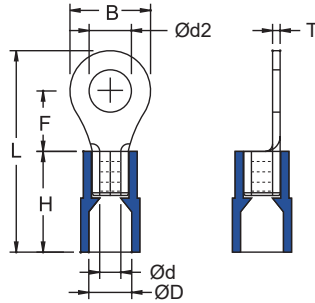

Part No.	Color	Wire Range		Dimension mm (inch)								Stud Size	
		sq. mm.	AWG	B	Ød2	L	F	H	Ød	ØD	T	mm	inch
EVR1-3	Red	0.5-1.5	22-16	5.5 (0.22)	3.2 (0.13)	18.0 (0.71)	4.8 (0.19)	10.5 (0.41)	1.7 (0.07)	4.1 (0.16)	0.75 (0.03)	M3	#4
EVR1-3.5				6.6 (0.26)	3.7 (0.15)	20.1 (0.79)	6.3 (0.25)					M3.5	#6
EVR1-4				8.0 (0.31)	4.3 (0.17)	21.5 (0.85)	7.0 (0.28)					M4	#8
EVR1-5				8.0 (0.31)	5.3 (0.21)	21.5 (0.85)	7.0 (0.28)					M5	#10
EVR1-6				11.6 (0.46)	6.4 (0.25)	27.4 (1.08)	11.1 (0.44)					M6	1/4
EVR1-8				11.6 (0.46)	8.4 (0.33)	27.4 (1.08)	11.1 (0.44)					M8	5/16
EVR1-10				13.6 (0.54)	10.5 (0.41)	31.2 (1.23)	13.9 (0.55)					M10	3/8
EVR1-12				19.0 (0.75)	13.0 (0.51)	36.1 (1.42)	16.0 (0.63)					M12	1/2
EVR2-3	Blue	1.5-2.5	16-14	6.6 (0.26)	3.2 (0.13)	18.6 (0.73)	4.3 (0.17)	11.0 (0.43)	2.3 (0.09)	4.5 (0.18)	0.8 (0.03)	M3	#4
EVR2-3.5				6.6 (0.26)	3.7 (0.15)	20.6 (0.81)	6.3 (0.25)					M3.5	#6
EVR2-4				8.5 (0.33)	4.3 (0.17)	23.0 (0.91)	7.8 (0.31)					M4	#8
EVR2-5				9.5 (0.37)	5.3 (0.21)	23.0 (0.91)	7.3 (0.29)					M5	#10
EVR2-6				12.0 (0.47)	6.4 (0.25)	28.0 (1.10)	11.0 (0.43)					M6	1/4
EVR2-8				12.0 (0.47)	8.4 (0.33)	28.0 (1.10)	11.0 (0.43)					M8	5/16
EVR2-10				13.6 (0.54)	10.5 (0.41)	31.7 (1.25)	13.9 (0.55)					M10	3/8
EVR2-12				19.0 (0.75)	13.0 (0.51)	36.6 (1.44)	16.0 (0.63)					M12	1/2
EVR5-3.5	Yellow	4-6	12-10	7.2 (0.28)	3.7 (0.15)	22.5 (0.89)	5.9 (0.23)	13.0 (0.51)	3.4 (0.13)	6.5 (0.26)	1.0 (0.04)	M3.5	#6
EVR5-4				9.5 (0.37)	4.3 (0.17)	26.0 (1.02)	8.3 (0.33)					M4	#8
EVR5-5				9.5 (0.37)	5.3 (0.21)	26.0 (1.02)	8.3 (0.33)					M5	#10
EVR5-6				12.0 (0.47)	6.4 (0.25)	29.5 (1.16)	10.5 (0.41)					M6	1/4
EVR5-8				15.0 (0.59)	8.4 (0.33)	34.2 (1.35)	13.7 (0.54)					M8	5/16
EVR5-10				15.0 (0.59)	10.5 (0.41)	34.2 (1.35)	13.7 (0.54)					M10	3/8
EVR5-12				19.2 (0.76)	13.0 (0.51)	38.6 (1.52)	16.0 (0.63)					M12	1/2

Wire Termination Terminals

VINYL-INSULATED RING TERMINALS (DOUBLE CRIMP)

- Ring tongue design assures a secure connection in high vibration applications
- Insulation support helps to prevent wire damage in bending applications
- The design of the easy-entry terminal makes the installation process easier
- Provide better conductivity and contact area
- Material: Copper tube with tin plated end sleeves with insulation PVC

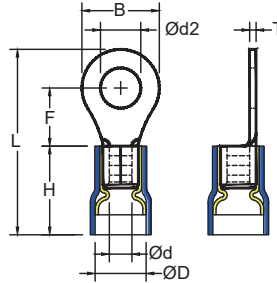

Part No.	Color	Wire Range		Dimension mm (inch)								Stud Size	
		sq. mm.	AWG	B	Ød2	L	F	H	Ød	ØD	T	mm	inch
EVR1-3C	Red	0.5-1.5	22-16	5.5 (0.22)	3.2 (0.13)	18.0 (0.71)	4.8 (0.19)	10.5 (0.41)	1.7 (0.07)	4.5 (0.18)	0.75 (0.03)	M3	#4
EVR1-3.5C				6.6 (0.26)	3.7 (0.15)	20.1 (0.79)	6.3 (0.25)					M3.5	#6
EVR1-4C				8.0 (0.31)	4.3 (0.17)	21.5 (0.85)	7.0 (0.28)					M4	#8
EVR1-5C				8.0 (0.31)	5.3 (0.21)	21.5 (0.85)	7.0 (0.28)					M5	#10
EVR1-6C				11.6 (0.46)	6.4 (0.25)	27.4 (1.08)	11.1 (0.44)					M6	1/4
EVR1-8C				11.6 (0.46)	8.4 (0.33)	27.4 (1.08)	11.1 (0.44)					M8	5/16
EVR1-10C				13.6 (0.54)	10.5 (0.41)	31.2 (1.23)	13.9 (0.55)					M10	3/8
EVR1-12C				19.0 (0.75)	13.0 (0.51)	36.1 (1.42)	16.0 (0.63)					M12	1/2
EVR2-3C	Blue	1.5-2.5	16-14	6.6 (0.26)	3.2 (0.13)	18.1 (0.71)	4.3 (0.17)	10.5 (0.41)	2.3 (0.09)	5.0 (0.20)	0.8 (0.03)	M3	#4
EVR2-3.5C				6.6 (0.26)	3.7 (0.15)	20.1 (0.79)	6.3 (0.25)					M3.5	#6
EVR2-4C				8.5 (0.33)	4.3 (0.17)	22.5 (0.89)	7.8 (0.31)					M4	#8
EVR2-5C				9.5 (0.37)	5.3 (0.21)	22.5 (0.89)	7.3 (0.29)					M5	#10
EVR2-6C				12.0 (0.47)	6.4 (0.25)	27.5 (1.08)	11.0 (0.43)					M6	1/4
EVR2-8C				12.0 (0.47)	8.4 (0.33)	27.5 (1.08)	11.0 (0.43)					M8	5/16
EVR2-10C				13.6 (0.54)	10.5 (0.41)	31.2 (1.23)	13.9 (0.55)					M10	3/8
EVR2-12C				19.0 (0.75)	13.0 (0.51)	36.1 (1.42)	16.0 (0.63)					M12	1/2
EVR5-3.5C	Yellow	4-6	12-10	7.2 (0.28)	3.7 (0.15)	22.5 (0.89)	5.9 (0.23)	13.0 (0.51)	3.4 (0.13)	6.7 (0.26)	1.0 (0.04)	M3.5	#6
EVR5-4C				9.5 (0.37)	4.3 (0.17)	26.0 (1.02)	8.3 (0.33)					M4	#8
EVR5-5C				9.5 (0.37)	5.3 (0.21)	26.0 (1.02)	8.3 (0.33)					M5	#10
EVR5-6C				12.0 (0.47)	6.4 (0.25)	29.5 (1.16)	10.5 (0.41)					M6	1/4
EVR5-8C				15.0 (0.59)	8.4 (0.33)	34.2 (1.35)	13.7 (0.54)					M8	5/16
EVR5-10C				15.0 (0.59)	10.5 (0.41)	34.2 (1.35)	13.7 (0.54)					M10	3/8
EVR5-12C				19.2 (0.76)	13.0 (0.51)	38.6 (1.52)	16.0 (0.63)					M12	1/2

NYLON-INSULATED RING TERMINALS (EASY-ENTRY)

- Ring tongue design assures a secure connection in high vibration applications
- Insulation support helps to prevent wire damage in bending applications
- The design of the easy-entry terminal makes the installation process easier
- Material: Copper tube with tin plated end sleeves with insulation Nylon

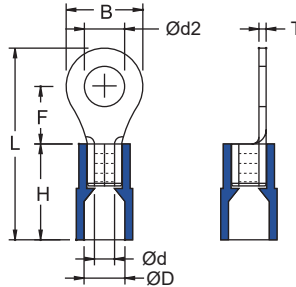

Part No.	Color	Wire Range		Dimension mm (inch)								Stud Size	
		sq. mm.	AWG	B	Ød2	L	F	H	Ød	ØD	T	mm	inch
ENR1-3	Red	0.5-1.5	22-16	5.5 (0.22)	3.2 (0.13)	18.5 (0.73)	4.8 (0.19)	10.5 (0.41)	1.7 (0.07)	4.1 (0.16)	0.75 (0.03)	M3	#4
ENR1-3.5				6.6 (0.26)	3.7 (0.15)	20.6 (0.81)	6.3 (0.25)					M3.5	#6
ENR1-4				8.0 (0.31)	4.3 (0.17)	22.0 (0.87)	7.0 (0.28)					M4	#8
ENR1-5				8.0 (0.31)	5.3 (0.21)	22.0 (0.87)	7.0 (0.28)					M5	#10
ENR1-6				11.6 (0.46)	6.4 (0.25)	27.9 (1.10)	11.1 (0.44)					M6	1/4
ENR1-8				11.6 (0.46)	8.4 (0.33)	27.9 (1.10)	11.1 (0.44)					M8	5/16
ENR1-10				13.6 (0.54)	10.5 (0.41)	31.7 (1.25)	13.9 (0.55)					M10	3/8
ENR1-12				19.0 (0.75)	13.0 (0.51)	36.6 (1.44)	16.0 (0.63)					M12	1/2
ENR2-3	Blue	1.5-2.5	16-14	6.6 (0.26)	3.2 (0.13)	18.6 (0.73)	4.3 (0.17)	11.0 (0.43)	2.3 (0.09)	4.5 (0.18)	0.8 (0.03)	M3	#4
ENR2-3.5				6.6 (0.26)	3.7 (0.15)	20.6 (0.81)	6.3 (0.25)					M3.5	#6
ENR2-4				8.5 (0.33)	4.3 (0.17)	23.0 (0.91)	7.8 (0.31)					M4	#8
ENR2-5				9.5 (0.37)	5.3 (0.21)	23.0 (0.91)	7.3 (0.29)					M5	#10
ENR2-6				12.0 (0.47)	6.4 (0.25)	28.0 (1.10)	11.0 (0.43)					M6	1/4
ENR2-8				12.0 (0.47)	8.4 (0.33)	28.0 (1.10)	11.0 (0.43)					M8	5/16
ENR2-10				13.6 (0.54)	10.5 (0.41)	31.7 (1.25)	13.9 (0.55)					M10	3/8
ENR2-12				19.0 (0.75)	13.0 (0.51)	36.6 (1.44)	16.0 (0.63)					M12	1/2
ENR5-3.5	Yellow	4-6	12-10	7.2 (0.28)	3.7 (0.15)	22.5 (0.89)	5.9 (0.23)	13.0 (0.51)	3.4 (0.13)	6.5 (0.26)	1.0 (0.04)	M3.5	#6
ENR5-4				9.5 (0.37)	4.3 (0.17)	26.0 (1.02)	8.3 (0.33)					M4	#8
ENR5-5				9.5 (0.37)	5.3 (0.21)	26.0 (1.02)	8.3 (0.33)					M5	#10
ENR5-6				12.0 (0.47)	6.4 (0.25)	29.5 (1.16)	10.5 (0.41)					M6	1/4
ENR5-8				15.0 (0.59)	8.4 (0.33)	34.2 (1.35)	13.7 (0.54)					M8	5/16
ENR5-10				15.0 (0.59)	10.5 (0.41)	34.2 (1.35)	13.7 (0.54)					M10	3/8
ENR5-12				19.2 (0.76)	13.0 (0.51)	38.6 (1.52)	16.0 (0.63)					M12	1/2

Wire Termination
Terminals

NYLON-INSULATED RING TERMINALS (DOUBLE CRIMP)

- Ring tongue design assures a secure connection in high vibration applications
- Insulation support helps to prevent wire damage in bending applications
- The design of the easy-entry terminal makes the installation process easier
- Provide better conductivity and contact area
- Material: Copper tube with tin plated end sleeves with insulation Nylon

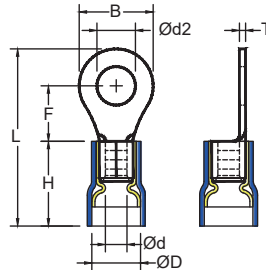

Part No.	Color	Wire Range		Dimension mm (inch)								Stud Size	
		sq. mm.	AWG	B	Ød2	L	F	H	Ød	ØD	T	mm	inch
ENR1-3C	Red	0.5-1.5	22-16	5.5 (0.22)	3.2 (0.13)	18.5 (0.73)	4.8 (0.19)	11.0 (0.43)	1.7 (0.07)	4.5 (0.18)	0.75 (0.03)	M3	#4
ENR1-3.5C				6.6 (0.26)	3.7 (0.15)	20.6 (0.81)	6.3 (0.25)					M3.5	#6
ENR1-4C				8.0 (0.31)	4.3 (0.17)	22.0 (0.87)	7.0 (0.28)					M4	#8
ENR1-5C				8.0 (0.31)	5.3 (0.21)	22.0 (0.87)	7.0 (0.28)					M5	#10
ENR1-6C				11.6 (0.46)	6.4 (0.25)	27.9 (1.10)	11.1 (0.44)					M6	1/4
ENR1-8C				11.6 (0.46)	8.4 (0.33)	27.9 (1.10)	11.1 (0.44)					M8	5/16
ENR1-10C				13.6 (0.54)	10.5 (0.41)	31.7 (1.25)	13.9 (0.55)					M10	3/8
ENR1-12C				19.0 (0.75)	13.0 (0.51)	36.6 (1.44)	16.0 (0.63)					M12	1/2
ENR2-3C	Blue	1.5-2.5	16-14	6.6 (0.26)	3.2 (0.13)	18.6 (0.73)	4.3 (0.17)	11.0 (0.43)	2.3 (0.09)	5.0 (0.20)	0.8 (0.03)	M3	#4
ENR2-3.5C				6.6 (0.26)	3.7 (0.15)	20.6 (0.81)	6.3 (0.25)					M3.5	#6
ENR2-4C				8.5 (0.33)	4.3 (0.17)	23.0 (0.91)	7.8 (0.31)					M4	#8
ENR2-5C				9.5 (0.37)	5.3 (0.21)	23.0 (0.91)	7.3 (0.29)					M5	#10
ENR2-6C				12.0 (0.47)	6.4 (0.25)	28.0 (1.10)	11.0 (0.43)					M6	1/4
ENR2-8C				12.0 (0.47)	8.4 (0.33)	28.0 (1.10)	11.0 (0.43)					M8	5/16
ENR2-10C				13.6 (0.54)	10.5 (0.41)	31.7 (1.25)	13.9 (0.55)					M10	3/8
ENR2-12C				19.0 (0.75)	13.0 (0.51)	36.6 (1.44)	16.0 (0.63)					M12	1/2
ENR5-3.5C	Yellow	4-6	12-10	7.2 (0.28)	3.7 (0.15)	22.5 (0.89)	5.9 (0.23)	13.0 (0.51)	3.4 (0.13)	6.7 (0.26)	1.0 (0.04)	M3.5	#6
ENR5-4C				9.5 (0.37)	4.3 (0.17)	26.0 (1.02)	8.3 (0.33)					M4	#8
ENR5-5C				9.5 (0.37)	5.3 (0.21)	26.0 (1.02)	8.3 (0.33)					M5	#10
ENR5-6C				12.0 (0.47)	6.4 (0.25)	29.5 (1.16)	10.5 (0.41)					M6	1/4
ENR5-8C				15.0 (0.59)	8.4 (0.33)	34.2 (1.35)	13.7 (0.54)					M8	5/16
ENR5-10C				15.0 (0.59)	10.5 (0.41)	34.2 (1.35)	13.7 (0.54)					M10	3/8
ENR5-12C				19.2 (0.76)	13.0 (0.51)	38.6 (1.52)	16.0 (0.63)					M12	1/2

INSULATED HEAT SHRINKABLE RING TERMINALS (BRAZED SEAM)

- Brazed seam protects terminal barrel from splitting during the crimping process
- Ring tongue design assures a secure connection in high vibration applications
- Fork design provides fast and easy installation without removing the fastener
- Insulation support helps to prevent wire damage in bending applications
- Provides excellent electrical insulation, sealing, waterproof, corrosion resistance and temperature resistance
- Material: Copper tube with tin plated end sleeves with insulation high density PE

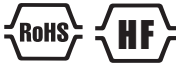
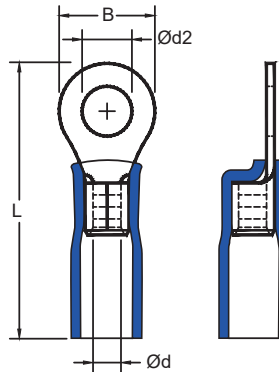

Part No.	Color	Wire Range		Dimension mm (inch)				Stud Size	
		sq. mm.	AWG	B	Ød2	L	Ød	mm	inch
HR1-4B	Red	0.5-1.5	22-16	8.0 (0.31)	4.3 (0.17)	28.0 (1.10)	1.7 (0.07)	M4	#8
HR1-5B				8.0 (0.31)	5.3 (0.21)	28.0 (1.10)		M5	#10
HR1-6B				11.6 (0.46)	6.4 (0.25)	34.0 (1.34)		M6	1/4
HR1-8B				11.6 (0.46)	8.4 (0.33)	34.0 (1.34)		M8	5/16
HR1-10B				13.6 (0.54)	10.5 (0.41)	38.0 (1.50)		M10	3/8
HR2-4B	Blue	1.5-2.5	16-14	8.5 (0.33)	4.3 (0.17)	29.0 (1.14)	2.3 (0.09)	M4	#8
HR2-5B				9.5 (0.37)	5.3 (0.21)	29.0 (1.14)		M5	#10
HR2-6B				12.0 (0.47)	6.4 (0.25)	34.0 (1.34)		M6	1/4
HR2-8B				12.0 (0.47)	8.4 (0.33)	34.0 (1.34)		M8	5/16
HR2-10B				13.6 (0.54)	10.5 (0.41)	38.0 (1.50)		M10	3/8
HR5-4B	Yellow	4-6	12-10	9.5 (0.37)	4.3 (0.17)	33.0 (1.30)	3.4 (0.13)	M4	#8
HR5-5B				9.5 (0.37)	5.3 (0.21)	33.0 (1.30)		M5	#10
HR5-6B				12.0 (0.47)	6.4 (0.25)	37.0 (1.46)		M6	1/4
HR5-8B				15.0 (0.59)	8.4 (0.33)	41.0 (1.61)		M8	5/16
HR5-10B				15.0 (0.59)	10.5 (0.41)	41.0 (1.61)		M10	3/8
HR5-12B				19.2 (0.76)	13.0 (0.51)	46.0 (1.81)		M12	1/2

Wire Termination
Terminals

NON-INSULATED RING DIN 46234 TERMINALS

- Brazed seam protects terminal barrel from splitting during the crimping process
- Material: Copper

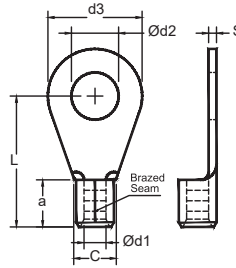

Part No.	Wire Range		Dimension mm (inch)							Stud Size
	sq. mm.	AWG	Ød3	Ød2	L	a	Ød1	C	S	mm
DR2.5-1B	0.5-1.5	22-16	6.0 (0.24)	2.7 (0.11)	11.0 (0.43)	5.0 (0.20)	1.6 (0.06)	4.0 (0.16)	0.8 (0.03)	M2.5
DR3-1B			6.0 (0.24)	3.2 (0.13)	11.0 (0.43)					M3
DR3.5-1B			6.0 (0.24)	3.7 (0.15)	11.0 (0.43)					M3.5
DR4-1B			8.0 (0.31)	4.3 (0.17)	12.0 (0.47)					M4
DR5-1B			10.0 (0.39)	5.3 (0.21)	13.0 (0.51)					M5
DR6-1B			11.0 (0.43)	6.5 (0.26)	16.0 (0.63)					M6
DR3-2.5B	1.5	16-14	6.0 (0.24)	3.2 (0.13)	11.0 (0.43)	5.0 (0.20)	2.3 (0.09)	4.5 (0.18)	0.8 (0.03)	M3
DR3.5-2.5B			6.0 (0.24)	3.7 (0.15)	11.0 (0.43)					M3.5
DR4-2.5B			8.0 (0.31)	4.3 (0.17)	12.0 (0.47)					M4
DR5-2.5B			10.0 (0.39)	5.3 (0.21)	14.0 (0.55)					M5
DR6-2.5B			11.0 (0.43)	6.5 (0.26)	16.0 (0.63)					M6
DR8-2.5B			14.0 (0.55)	8.4 (0.33)	17.0 (0.67)					M8
DR4-6B	4-6	12-10	8.0 (0.31)	4.3 (0.17)	14.0 (0.55)	6.0 (0.24)	3.6 (0.14)	6.0 (0.24)	1.0 (0.04)	M4
DR5-6B			10.0 (0.39)	5.3 (0.21)	15.0 (0.59)					M5
DR6-6B			11.0 (0.43)	6.5 (0.26)	16.0 (0.63)					M6
DR8-6B			14.0 (0.55)	8.4 (0.33)	19.0 (0.75)					M8
DR10-6B			18.0 (0.71)	10.5 (0.41)	21.0 (0.83)					M10
DR12-6B			18.0 (0.71)	13.0 (0.51)	21.0 (0.83)					M12
DR5-10B	10	8	10.0 (0.39)	5.3 (0.21)	16.0 (0.63)	8.0 (0.31)	4.5 (0.18)	8.0 (0.31)	1.1 (0.04)	M5
DR6-10B			11.0 (0.43)	6.5 (0.26)	17.0 (0.67)					M6
DR8-10B			14.0 (0.55)	8.4 (0.33)	20.0 (0.79)					M8
DR10-10B			18.0 (0.71)	10.5 (0.41)	21.0 (0.83)					M10
DR12-10B			22.0 (0.87)	13.0 (0.51)	23.0 (0.91)					M12
DR5-16B	16	6	11.0 (0.43)	5.3 (0.21)	20.0 (0.79)	10.0 (0.39)	5.8 (0.23)	10.5 (0.41)	1.2 (0.05)	M5
DR6-16B			11.0 (0.43)	6.5 (0.26)	20.0 (0.79)					M6
DR8-16B			14.0 (0.55)	8.4 (0.33)	22.0 (0.87)					M8
DR10-16B			18.0 (0.71)	10.5 (0.41)	24.0 (0.94)					M10
DR12-16B			22.0 (0.87)	13.0 (0.51)	26.0 (1.02)					M12
DR5-25B	25	4	12.0 (0.47)	5.3 (0.21)	25.0 (0.98)	11.0 (0.43)	7.5 (0.30)	12.0 (0.47)	1.5 (0.06)	M5
DR6-25B			12.0 (0.47)	6.5 (0.26)	25.0 (0.98)					M6
DR8-25B			16.0 (0.63)	8.4 (0.33)	25.0 (0.98)					M8
DR10-25B			18.0 (0.71)	10.5 (0.41)	26.0 (1.02)					M10
DR12-25B			22.0 (0.87)	13.0 (0.51)	31.0 (1.22)					M12
DR16-25B			28.0 (1.10)	17.0 (0.67)	35.0 (1.38)					M16

*DIN46234

NON-INSULATED RING DIN 46234 TERMINALS

- Brazed seam protects terminal barrel from splitting during the crimping process
- Material: Copper

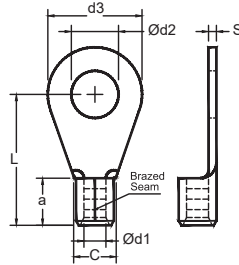

Part No.	Wire Range		Dimension mm (inch)							Stud Size mm
	sq. mm.	AWG	Ød3	Ød2	L	a	Ød1	C	S	
DR6-35B	35	2	15.0 (0.59)	6.5 (0.26)	26.0 (1.02)	12.0 (0.47)	9.0 (0.35)	15.0 (0.59)	1.6 (0.06)	M6
DR8-35B			16.0 (0.63)	8.4 (0.33)	26.0 (1.02)					M8
DR10-35B			18.0 (0.71)	10.5 (0.41)	27.0 (1.06)					M10
DR12-35B			22.0 (0.87)	13.0 (0.51)	31.0 (1.22)					M12
DR16-35B			28.0 (1.10)	17.0 (0.67)	36.0 (1.42)					M16
DR6-50B	50	1/0	18.0 (0.71)	6.5 (0.26)	34.0 (1.34)	16.0 (0.63)	11.0 (0.43)	17.0 (0.67)	1.8 (0.07)	M6
DR8-50B			18.0 (0.71)	8.0 (0.31)	34.0 (1.34)					M8
DR10-50B			18.0 (0.71)	10.5 (0.41)	34.0 (1.34)					M10
DR12-50B			22.0 (0.87)	13.0 (0.51)	36.0 (1.42)					M12
DR16-50B			28.0 (1.10)	17.0 (0.67)	40.0 (1.57)					M16
DR6-70B	70	2/0	22.0 (0.87)	6.5 (0.26)	38.0 (1.50)	18.0 (0.71)	13.0 (0.51)	21.0 (0.83)	2.0 (0.08)	M6
DR8-70B			22.0 (0.87)	8.4 (0.33)	38.0 (1.50)					M8
DR10-70B			22.0 (0.87)	10.5 (0.41)	38.0 (1.50)					M10
DR12-70B			22.0 (0.87)	13.0 (0.51)	38.0 (1.50)					M12
DR16-70B			28.0 (1.10)	17.0 (0.67)	42.0 (1.65)					M16
DR8-95B	95	3/0	24.0 (0.94)	8.4 (0.33)	42.0 (1.65)	20.0 (0.79)	15.0 (0.59)	23.0 (0.91)	2.5 (0.1)	M8
DR10-95B			24.0 (0.94)	10.5 (0.41)	42.0 (1.65)					M10
DR12-95B			24.0 (0.94)	13.0 (0.51)	42.0 (1.65)					M12
DR16-95B			28.0 (1.10)	17.0 (0.67)	44.0 (1.73)					M16
DR8-120B	120	4/0	24.0 (0.94)	8.4 (0.33)	44.0 (1.73)	22.0 (0.87)	16.5 (0.65)	24.0 (0.94)	3.0 (0.12)	M8
DR10-120B			24.0 (0.94)	10.5 (0.41)	44.0 (1.73)					M10
DR12-120B			24.0 (0.94)	13.0 (0.51)	44.0 (1.73)					M12
DR16-120B			28.0 (1.10)	17.0 (0.67)	48.0 (1.89)					M16

VINYL-INSULATED DIN 46237 RING TERMINALS

- Insulation support helps to prevent wire damage in bending applications
- Material: Copper tube with tin plated end sleeves with insulation PVC

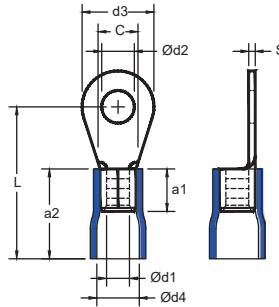

Part No.	Color	Wire Range		Dimension mm (inch)									Stud Size mm
		sq. mm.	AWG	d3	Ød2	C	L	a1	a2	Ød1	Ød4	s	
VDR2.5-1B	Red	0.5-1.5	22-16	6.0 (0.24)	2.7 (0.11)	4.0 (0.16)	16.0 (0.63)	5.0 (0.2)	10.0 (0.39)	1.6 (0.06)	4.2 (0.17)	0.8 (0.03)	M2.5
VDR3-1B				6.0 (0.24)	3.2 (0.13)	4.0 (0.16)	16.0 (0.63)						M3
VDR3.5-1B				6.0 (0.24)	3.7 (0.15)	4.0 (0.16)	16.0 (0.63)						M3.5
VDR4-1B				8.0 (0.31)	4.3 (0.17)	4.0 (0.16)	17.0 (0.67)						M4
VDR5-1B				10.0 (0.39)	5.3 (0.21)	4.0 (0.16)	18.0 (0.71)						M5
VDR6-1B				11.0 (0.43)	6.5 (0.26)	4.0 (0.16)	21.0 (0.83)						M6
VDR3-2.5B	Blue	1.5-2.5	16-14	6.0 (0.24)	3.2 (0.13)	4.5 (0.18)	16.0 (0.63)	5.0 (0.2)	10.0 (0.39)	2.3 (0.09)	4.6 (0.18)	0.8 (0.03)	M3
VDR3.5-2.5B				6.0 (0.24)	3.7 (0.15)	4.5 (0.18)	16.0 (0.63)						M3.5
VDR4-2.5B				8.0 (0.31)	4.3 (0.17)	4.5 (0.18)	17.0 (0.67)						M4
VDR5-2.5B				10.0 (0.39)	5.3 (0.21)	4.5 (0.18)	19.0 (0.75)						M5
VDR6-2.5B				11.0 (0.43)	6.5 (0.26)	4.5 (0.18)	21.0 (0.83)						M6
VDR8-2.5B				14.0 (0.55)	8.4 (0.33)	4.5 (0.18)	22.0 (0.87)						M8
VDR4-6B	Yellow	4-6	12-10	8.0 (0.31)	4.3 (0.17)	6.0 (0.24)	21.0 (0.83)	6.0 (0.24)	13.0 (0.51)	3.6 (0.14)	6.6 (0.26)	1.0 (0.04)	M4
VDR5-6B				10.0 (0.39)	5.3 (0.21)	6.0 (0.24)	22.0 (0.87)						M5
VDR6-6B				11.0 (0.43)	6.5 (0.26)	6.0 (0.24)	23.0 (0.91)						M6
VDR8-6B				14.0 (0.55)	8.4 (0.33)	6.0 (0.24)	26.0 (1.02)						M8
VDR10-6B				18.0 (0.71)	10.5 (0.41)	6.0 (0.24)	28.0 (1.10)						M10
VDR12-6B				18.0 (0.71)	13.0 (0.51)	6.0 (0.24)	28.0 (1.10)						M12

*DIN46237

VINYL-INSULATED DIN 46237 RING TERMINALS (DOUBLE CRIMP)

- Ring tongue design assures a secure connection in high vibration applications
- Insulation support helps to prevent wire damage in bending applications
- The design of the easy-entry terminal makes the installation process easier
- Provide better conductivity and contact area
- Material: Copper tube with tin plated end sleeves with insulation PVC

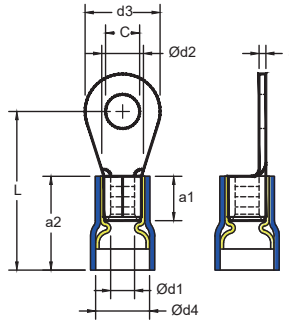

Part No.	Color	Wire Range		Dimension mm (inch)									Stud Size
		sq. mm.	AWG	d3	Ød2	C	L	a1	a2	Ød1	Ød4	s	mm
EVDR2.5-1C	Red	0.5-1.5	22-16	6.0 (0.24)	2.7 (0.11)	4.0 (0.16)	16.5 (0.65)	5.0 (0.20)	10.5 (0.41)	1.6 (0.06)	4.5 (0.18)	0.8 (0.03)	M2.5
EVDR3-1C				6.0 (0.24)	3.2 (0.13)	4.0 (0.16)	16.5 (0.65)						M3
EVDR3.5-1C				6.0 (0.24)	3.7 (0.15)	4.0 (0.16)	16.5 (0.65)						M3.5
EVDR4-1C				8.0 (0.31)	4.3 (0.17)	4.0 (0.16)	17.5 (0.69)						M4
EVDR5-1C				10.0 (0.39)	5.3 (0.21)	4.0 (0.16)	18.5 (0.73)						M5
EVDR6-1C				11.0 (0.43)	6.5 (0.26)	4.0 (0.16)	21.5 (0.85)						M6
EVDR8-1C				14.0 (0.55)	8.4 (0.33)	4.0 (0.16)	22.5 (0.89)						M8
EVDR3-2.5C				Blue	1.5-2.5	16-14	6.0 (0.24)						3.2 (0.13)
EVDR3.5-2.5C	6.0 (0.24)	3.7 (0.15)	4.5 (0.18)				16.5 (0.65)	M3.5					
EVDR4-2.5C	8.0 (0.31)	4.3 (0.17)	4.5 (0.18)				17.5 (0.69)	M4					
EVDR5-2.5C	10.0 (0.39)	5.3 (0.21)	4.5 (0.18)				19.5 (0.77)	M5					
EVDR6-2.5C	11.0 (0.43)	6.5 (0.26)	4.5 (0.18)				21.5 (0.85)	M6					
EVDR8-2.5C	14.0 (0.55)	8.4 (0.33)	4.5 (0.18)				22.5 (0.89)	M8					
EVDR10-2.5C	18.0 (0.71)	10.5 (0.41)	4.5 (0.18)				25.5 (1.00)	M10					
EVDR4-6C	Yellow	4-6	12-10				8.0 (0.31)	4.3 (0.17)	6.0 (0.24)	21.0 (0.83)	6.0 (0.24)	13 (0.51)	3.6 (0.14)
EVDR5-6C				10.0 (0.39)	5.3 (0.21)	6.0 (0.24)	22.0 (0.87)	M5					
EVDR6-6C				11.0 (0.43)	6.5 (0.26)	6.0 (0.24)	23.0 (0.91)	M6					
EVDR8-6C				14.0 (0.55)	8.4 (0.33)	6.0 (0.24)	26.0 (1.02)	M8					
EVDR10-6C				18.0 (0.71)	10.5 (0.41)	6.0 (0.24)	28.0 (1.10)	M10					
EVDR12-6C				18.0 (0.71)	13.0 (0.51)	6.0 (0.24)	28.0 (1.10)	M12					

*DIN46234

NYLON-INSULATED DIN 46237 RING TERMINALS (EASY-ENTRY)

- Ring tongue design assures a secure connection in high vibration applications
- Insulation support helps to prevent wire damage in bending applications
- The design of the easy-entry terminal makes the installation process easier
- Material: Copper tube with tin plated end sleeves with insulation Nylon

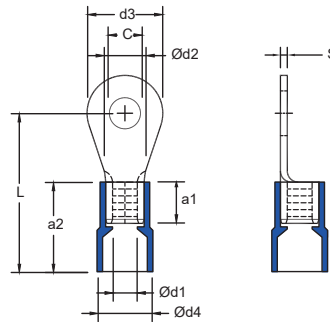

Part No.	Color	Wire Range		Dimension mm (inch)									Stud Size
		sq. mm.	AWG	d3	Ød2	C	L	a1	a2	Ød1	Ød4	s	mm
ENDR2.5-1	Red	0.5-1.5	22-16	6.0 (0.24)	2.7 (0.11)	4.0 (0.16)	17.0 (0.67)	5.0 (0.20)	10.5 (0.41)	1.6 (0.06)	4.1 (0.16)	0.8 (0.03)	M2.5
ENDR3-1				6.0 (0.24)	3.2 (0.13)	4.0 (0.16)	17.0 (0.67)						M3
ENDR3.5-1				6.0 (0.24)	3.7 (0.15)	4.0 (0.16)	17.0 (0.67)						M3.5
ENDR4-1				8.0 (0.31)	4.3 (0.17)	4.0 (0.16)	18.0 (0.71)						M4
ENDR5-1				10.0 (0.39)	5.3 (0.21)	4.0 (0.16)	19.0 (0.75)						M5
ENDR6-1				11.0 (0.43)	6.5 (0.26)	4.0 (0.16)	22.0 (0.87)						M6
ENDR8-1				14.0 (0.55)	8.4 (0.33)	4.0 (0.16)	23.0 (0.91)						M8
ENDR3-2.5	Blue	1.5-2.5	16-14	6.0 (0.24)	3.2 (0.13)	4.5 (0.18)	17.0 (0.67)	5.0 (0.20)	11.0 (0.43)	2.3 (0.09)	4.5 (0.18)	0.8 (0.03)	M3
ENDR3.5-2.5				6.0 (0.24)	3.7 (0.15)	4.5 (0.18)	17.0 (0.67)						M3.5
ENDR4-2.5				8.0 (0.31)	4.3 (0.17)	4.5 (0.18)	18.0 (0.71)						M4
ENDR5-2.5				10.0 (0.39)	5.3 (0.21)	4.5 (0.18)	20.0 (0.79)						M5
ENDR6-2.5				11.0 (0.43)	6.5 (0.26)	4.5 (0.18)	22.0 (0.87)						M6
ENDR8-2.5				14.0 (0.55)	8.4 (0.33)	4.5 (0.18)	23.0 (0.91)						M8
ENDR10-2.5				18.0 (0.71)	10.5 (0.41)	4.5 (0.18)	26.0 (1.02)						M10
ENDR4-6	Yellow	4-6	12-10	8.0 (0.31)	4.3 (0.17)	6.0 (0.24)	21.0 (0.83)	6.0 (0.24)	13 (0.51)	3.6 (0.14)	6.5 (0.26)	1.0 (0.04)	M4
ENDR5-6				10.0 (0.39)	5.3 (0.21)	6.0 (0.24)	22.0 (0.87)						M5
ENDR6-6				11.0 (0.43)	6.5 (0.26)	6.0 (0.24)	23.0 (0.91)						M6
ENDR8-6				14.0 (0.55)	8.4 (0.33)	6.0 (0.24)	26.0 (1.02)						M8
ENDR10-6				18.0 (0.71)	10.5 (0.41)	6.0 (0.24)	28.0 (1.10)						M10
ENDR12-6				18.0 (0.71)	13.0 (0.51)	6.0 (0.24)	28.0 (1.10)						M12

NYLON-INSULATED DIN 46237 RING TERMINALS (DOUBLE CRIMP)

- Ring tongue design assures a secure connection in high vibration applications
- Insulation support helps to prevent wire damage in bending applications
- The design of the easy-entry terminal makes the installation process easier
- Provide better conductivity and contact area
- Material: Copper tube with tin plated end sleeves with insulation Nylon

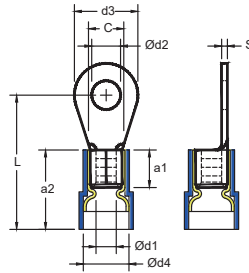

Part No.	Color	Wire Range		Dimension mm (inch)									Stud Size
		sq. mm.	AWG	d3	Ød2	C	L	a1	a2	Ød1	Ød4	s	mm
ENDR2.5-1C	Red	0.5-1.5	22-16	6.0 (0.24)	2.7 (0.11)	4.0 (0.16)	17.0 (0.67)	5.0 (0.20)	11.0 (0.43)	1.6 (0.06)	4.5 (0.18)	0.8 (0.03)	M2.5
ENDR3-1C				6.0 (0.24)	3.2 (0.13)	4.0 (0.16)	17.0 (0.67)						M3
ENDR3.5-1C				6.0 (0.24)	3.7 (0.15)	4.0 (0.16)	17.0 (0.67)						M3.5
ENDR4-1C				8.0 (0.31)	4.3 (0.17)	4.0 (0.16)	18.0 (0.71)						M4
ENDR5-1C				10.0 (0.39)	5.3 (0.21)	4.0 (0.16)	19.0 (0.75)						M5
ENDR6-1C				11.0 (0.43)	6.5 (0.26)	4.0 (0.16)	22.0 (0.87)						M6
ENDR8-1C				14.0 (0.55)	8.4 (0.33)	4.0 (0.16)	23.0 (0.91)						M8
ENDR3-2.5C	Blue	1.5-2.5	16-14	6.0 (0.24)	3.2 (0.13)	4.5 (0.18)	17.0 (0.67)	5.0 (0.20)	11.0 (0.43)	2.3 (0.09)	5.0 (0.20)	0.8 (0.03)	M3
ENDR3.5-2.5C				6.0 (0.24)	3.7 (0.15)	4.5 (0.18)	17.0 (0.67)						M3.5
ENDR4-2.5C				8.0 (0.31)	4.3 (0.17)	4.5 (0.18)	18.0 (0.71)						M4
ENDR5-2.5C				10.0 (0.39)	5.3 (0.21)	4.5 (0.18)	20.0 (0.79)						M5
ENDR6-2.5C				11.0 (0.43)	6.5 (0.26)	4.5 (0.18)	22.0 (0.87)						M6
ENDR8-2.5C				14.0 (0.55)	8.4 (0.33)	4.5 (0.18)	23.0 (0.91)						M8
ENDR10-2.5C				18.0 (0.71)	10.5 (0.41)	4.5 (0.18)	26.0 (1.02)						M10
ENDR4-6C	Yellow	4-6	12-10	8.0 (0.31)	4.3 (0.17)	6.0 (0.24)	21.0 (0.83)	6.0 (0.24)	13 (0.51)	3.6 (0.14)	6.7 (0.26)	1.0 (0.04)	M4
ENDR5-6C				10.0 (0.39)	5.3 (0.21)	6.0 (0.24)	22.0 (0.87)						M5
ENDR6-6C				11.0 (0.43)	6.5 (0.26)	6.0 (0.24)	23.0 (0.91)						M6
ENDR8-6C				14.0 (0.55)	8.4 (0.33)	6.0 (0.24)	26.0 (1.02)						M8
ENDR10-6C				18.0 (0.71)	10.5 (0.41)	6.0 (0.24)	28.0 (1.10)						M10
ENDR12-6C				18.0 (0.71)	13.0 (0.51)	6.0 (0.24)	28.0 (1.10)						M12

NON-INSULATED SPADE TERMINALS

- Fork design provides fast and easy installation without removing the fastener
- Brazed seam protects terminal barrel from splitting during the crimping process
- Material: Copper

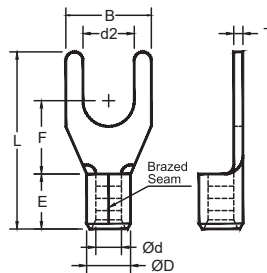

Part No.	Wire Range		Dimension mm (inch)								Stud Size	
	sq. mm.	AWG	B	d2	L	F	E	Ød	ØD	T	mm	inch
Y1-3B	0.5-1.5	22-16	5.8 (0.23)	3.2 (0.13)	16.0 (0.63)	6.3 (0.25)	5.0 (0.20)	1.7 (0.07)	3.4 (0.13)	0.75 (0.03)	M3	#4
Y1-3.5B			6.4 (0.25)	3.7 (0.15)	16.0 (0.63)	6.3 (0.25)					M3.5	#6
Y1-4B			7.2 (0.28)	4.3 (0.17)	16.0 (0.63)	6.3 (0.25)					M4	#8
Y1-5B			8.1 (0.32)	5.3 (0.21)	16.7 (0.66)	7.0 (0.28)					M5	#10
Y1-6B			12.0 (0.47)	6.4 (0.25)	22.4 (0.88)	11.0 (0.43)					M6	1/4
Y2-3B	1.5-2.5	16-14	5.8 (0.23)	3.2 (0.13)	16.2 (0.64)	6.5 (0.26)	5.0 (0.20)	2.3 (0.09)	4.1 (0.16)	0.8 (0.03)	M3	#4
Y2-3.5B			6.4 (0.25)	3.7 (0.15)	16.2 (0.64)	6.5 (0.26)					M3.5	#6
Y2-4B			7.2 (0.28)	4.3 (0.17)	16.2 (0.64)	6.5 (0.26)					M4	#8
Y2-5B			8.5 (0.33)	5.3 (0.21)	17.0 (0.67)	7.3 (0.29)					M5	#10
Y2-6B			12.0 (0.47)	6.4 (0.25)	22.4 (0.88)	11.0 (0.43)					M6	1/4
Y3-3.5B	2.5-4	12-10	8.0 (0.31)	3.7 (0.15)	18.3 (0.72)	7.0 (0.28)	6.0 (0.24)	2.9 (0.11)	5.1 (0.20)	1.0 (0.04)	M3.5	#6
Y3-4B			8.0 (0.31)	4.3 (0.17)	18.3 (0.72)	7.0 (0.28)					M4	#8
Y3-5B			8.0 (0.31)	5.3 (0.21)	18.3 (0.72)	7.0 (0.28)					M5	#10
Y5-3.5B	4-6	12-10	8.3 (0.33)	3.7 (0.15)	19.0 (0.75)	7.5 (0.30)	6.0 (0.24)	3.4 (0.13)	5.6 (0.22)	1.0 (0.04)	M3.5	#6
Y5-4B			9.5 (0.37)	4.3 (0.17)	18.7 (0.74)	7.5 (0.30)					M4	#8
Y5-5B			9.5 (0.37)	5.3 (0.21)	18.7 (0.74)	7.5 (0.30)					M5	#10
Y5-6B			12.0 (0.47)	6.4 (0.25)	24.7 (0.97)	12.0 (0.47)					M6	1/4
Y5-8B			13.5 (0.53)	8.4 (0.33)	24.7 (0.97)	12.2 (0.48)					M8	5/16

GOLD PLATED NON INSULATED SPADE TERMINALS (BRAZED SEAM)

- Brazed seam protects terminal barrel from splitting during the crimping process
- It has excellent electrical conductivity, strong corrosion resistance and oxidation resistance, and good stability
- Fork design provides fast and easy installation without removing the fastener
- Material: Copper with gold plating
- Terminals Soft Sleeves for Extra Quote

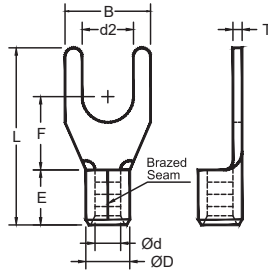

Part No.	Wire Range		Dimension mm (inch)								Stud Size	
	sq. mm.	AWG	B	Ød2	L	F	E	Ød	ØD	T	mm	inch
GY1-3B	0.5-1.5	22-16	5.8 (0.23)	3.2 (0.13)	16.0 (0.63)	6.3 (0.25)	5.0 (0.2)	1.7 (0.07)	3.4 (0.13)	0.75 (0.03)	M3	#4
GY1-3.5B			6.4 (0.25)	3.7 (0.15)	16.0 (0.63)	6.3 (0.25)					M3.5	#6
GY1-4B			7.2 (0.28)	4.3 (0.17)	16.0 (0.63)	6.3 (0.25)					M4	#8
GY1-5B			9.5 (0.37)	5.3 (0.21)	16.7 (0.66)	7.0 (0.28)					M5	#10
GY1-6B			12.0 (0.47)	6.4 (0.25)	22.4 (0.88)	11.0 (0.43)					M6	1/4
GY2-3B	1.5-2.5	16-14	5.8 (0.23)	3.2 (0.13)	16.2 (0.64)	6.5 (0.26)	5.0 (0.2)	2.3 (0.09)	4.1 (0.16)	0.8 (0.03)	M3	#4
GY2-3.5B			6.4 (0.25)	3.7 (0.15)	16.2 (0.64)	6.5 (0.26)					M3.5	#6
GY2-4B			7.2 (0.28)	4.3 (0.17)	16.2 (0.64)	6.5 (0.26)					M4	#8
GY2-5B			9.5 (0.37)	5.3 (0.21)	16.7 (0.66)	7.0 (0.28)					M5	#10
GY2-6B			12.0 (0.47)	6.4 (0.25)	22.4 (0.88)	11.0 (0.43)					M6	1/4
GY3-3.5B	2.5-4	14-12	8.0 (0.31)	3.7 (0.15)	18.3 (0.72)	7.0 (0.28)	6.0 (0.24)	2.9 (0.11)	5.1 (0.2)	1.0 (0.04)	M3.5	#6
GY3-4B			8.0 (0.31)	4.3 (0.17)	18.3 (0.72)	7.0 (0.28)					M4	#8
GY3-5B			8.0 (0.31)	5.3 (0.21)	18.3 (0.72)	7.0 (0.28)					M5	#10
GY3-6B			12.0 (0.47)	6.4 (0.25)	21.5 (0.85)	9.1 (0.36)					M6	1/4
GY5-3.5B	4-6	12-10	8.3 (0.33)	3.7 (0.15)	19.0 (0.75)	7.5 (0.30)	6.0 (0.24)	3.4 (0.13)	5.6 (0.22)	1.0 (0.04)	M3.5	#6
GY5-4B			9.5 (0.37)	4.3 (0.17)	18.7 (0.74)	7.5 (0.30)					M4	#8
GY5-5B			9.5 (0.37)	5.3 (0.21)	18.7 (0.74)	7.5 (0.30)					M5	#10
GY5-6B			12.0 (0.47)	6.4 (0.25)	24.7 (0.97)	12.0 (0.47)					M6	1/4
GY5-8B			13.5 (0.53)	8.4 (0.33)	24.7 (0.97)	12.2 (0.48)					M8	5/16
GY8-5B	8	8	10.5 (0.41)	5.3 (0.21)	20.8 (0.82)	8.1 (0.32)	8.5 (0.33)	4.5 (0.18)	7.2 (0.28)	1.2 (0.05)	M5	#10
GY8-6B			10.8 (0.43)	6.4 (0.25)	22.5 (0.89)	8.6 (0.34)					M6	1/4
GY14-6B	14	6	11.0 (0.43)	6.4 (0.25)	25.5 (1.00)	10.7 (0.42)	10.5 (0.41)	5.8 (0.23)	9.0 (0.35)	1.5 (0.06)	M6	1/4
GY14-8B			13.8 (0.54)	8.4 (0.33)	28.5 (1.12)	10.7 (0.42)					M8	5/16

VINYL-INSULATED SPADE TERMINALS

- Fork design provides fast and easy installation without removing the fastener
- Insulation support helps to prevent wire damage in bending applications
- Material: Copper tube with tin plated end sleeves with insulation PVC

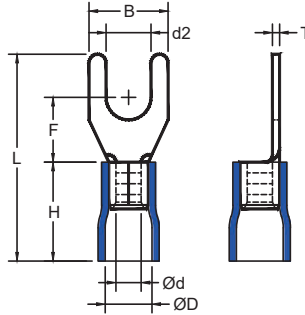

Part No.	Color	Wire Range		Dimension mm (inch)								Stud Size	
		sq. mm.	AWG	B	d2	L	F	H	ØD	Ød	T	mm	inch
VY1-3	Red	0.5-1.5	22-16	5.8 (0.23)	3.2 (0.13)	21.0 (0.83)	6.3 (0.25)	10.0 (0.39)	4.2 (0.17)	1.7 (0.07)	0.75 (0.03)	M3	#4
VY1-3.5				6.4 (0.25)	3.7 (0.15)	21.0 (0.83)	6.3 (0.25)					M3.5	#6
VY1-4				7.2 (0.28)	4.3 (0.17)	21.0 (0.83)	6.3 (0.25)					M4	#8
VY1-5				9.5 (0.37)	5.3 (0.21)	21.7 (0.85)	7.0 (0.28)					M5	#10
VY1-6				12.0 (0.47)	6.4 (0.25)	27.4 (1.08)	11.0 (0.43)					M6	1/4
VY2-3	Blue	1.5-2.5	16-14	5.8 (0.23)	3.2 (0.13)	21.2 (0.83)	6.5 (0.26)	10.0 (0.39)	4.6 (0.18)	2.3 (0.09)	0.8 (0.03)	M3	#4
VY2-3.5				6.4 (0.25)	3.7 (0.15)	21.2 (0.83)	6.5 (0.26)					M3.5	#6
VY2-4				7.2 (0.28)	4.3 (0.17)	21.2 (0.83)	6.5 (0.26)					M4	#8
VY2-5				9.5 (0.37)	5.3 (0.21)	21.7 (0.85)	7.0 (0.28)					M5	#10
VY2-6				12.0 (0.47)	6.4 (0.25)	27.4 (1.08)	11.0 (0.43)					M6	1/4
VY5-3.5	Yellow	4-6	12-10	8.3 (0.33)	3.7 (0.15)	26 (1.02)	7.5 (0.30)	13.0 (0.51)	6.5 (0.26)	3.4 (0.13)	1.0 (0.04)	M3.5	#6
VY5-4				9.5 (0.37)	4.3 (0.17)	25.7 (1.01)	7.5 (0.30)					M4	#8
VY5-5				9.5 (0.37)	5.3 (0.21)	25.7 (1.01)	7.5 (0.30)					M5	#10
VY5-6				12.0 (0.47)	6.4 (0.25)	31.7 (1.25)	12.0 (0.47)					M6	1/4
VY5-8				13.5 (0.53)	8.4 (0.33)	31.7 (1.25)	12.2 (0.48)					M8	5/16

VINYL-INSULATED SPADE TERMINALS (EASY-ENTRY)

- Fork design provides fast and easy installation without removing the fastener
- Insulation support helps to prevent wire damage in bending applications
- The design of the easy-entry terminal makes the installation process easier
- Material: Copper tube with tin plated end sleeves with insulation PVC

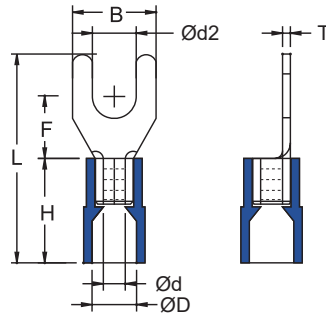

Part No.	Color	Wire Range		Dimension mm (inch)								Stud Size	
		sq. mm.	AWG	B	d2	L	F	H	ØD	Ød	T	mm	inch
EVY1-3	Red	0.5-1.5	22-16	5.8 (0.23)	3.2 (0.13)	21.5 (0.85)	6.3 (0.25)	10.0 (0.39)	4.1 (0.16)	1.7 (0.07)	0.75 (0.03)	M3	#4
EVY1-3.5				6.4 (0.25)	3.7 (0.15)	21.5 (0.85)	6.3 (0.25)					M3.5	#6
EVY1-4				7.2 (0.28)	4.3 (0.17)	21.5 (0.85)	6.3 (0.25)					M4	#8
EVY1-5				9.5 (0.37)	5.3 (0.21)	22.2 (0.87)	7.0 (0.28)					M5	#10
EVY1-6				12.0 (0.47)	6.4 (0.25)	27.9 (1.10)	11.0 (0.43)					M6	1/4
EVY2-3				Blue	1.5-2.5	16-14	5.8 (0.23)					3.2 (0.13)	22.2 (0.87)
EVY2-3.5	6.4 (0.25)	3.7 (0.15)	22.2 (0.87)				6.5 (0.26)	M3.5	#6				
EVY2-4	7.2 (0.28)	4.3 (0.17)	22.2 (0.87)				6.5 (0.26)	M4	#8				
EVY2-5	9.5 (0.37)	5.3 (0.21)	22.7 (0.89)				7.0 (0.28)	M5	#10				
EVY2-6	12.0 (0.47)	6.4 (0.25)	28.4 (1.12)				11.0 (0.43)	M6	1/4				
EVY5-3.5	Yellow	4-6	12-10				8.3 (0.33)	3.7 (0.15)	26.0 (1.02)	7.5 (0.30)	13.0 (0.51)	6.5 (0.26)	3.4 (0.13)
EVY5-4				9.5 (0.37)	4.3 (0.17)	25.7 (1.01)	7.5 (0.30)	M4	#8				
EVY5-5				9.5 (0.37)	5.3 (0.21)	25.7 (1.01)	7.5 (0.30)	M5	#10				
EVY5-6				12.0 (0.47)	6.4 (0.25)	31.7 (1.25)	12.0 (0.47)	M6	1/4				
EVY5-8				13.5 (0.53)	8.4 (0.33)	31.7 (1.25)	12.2 (0.48)	M8	5/16				

VINYL-INSULATED SPADE TERMINALS (DOUBLE CRIMP)

- Fork design provides fast and easy installation without removing the fastener
- Insulation support helps to prevent wire damage in bending applications
- The design of the easy-entry terminal makes the installation process easier
- Provide better conductivity and contact area
- Material: Copper tube with tin plated end sleeves with insulation PVC

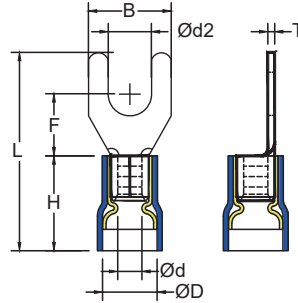

Part No.	Color	Wire Range		Dimension mm (inch)								Stud Size	
		sq. mm.	AWG	B	d2	L	F	H	ØD	Ød	T	mm	inch
EVY1-3C	Red	0.5-1.5	22-16	5.8 (0.23)	3.2 (0.13)	21.5 (0.85)	6.3 (0.25)	10.5 (0.41)	4.5 (0.18)	1.7 (0.07)	0.75 (0.03)	M3	#4
EVY1-3.5C				6.4 (0.25)	3.7 (0.15)	21.5 (0.85)	6.3 (0.25)					M3.5	#6
EVY1-4C				7.2 (0.28)	4.3 (0.17)	21.5 (0.85)	6.3 (0.25)					M4	#8
EVY1-5C				9.5 (0.37)	5.3 (0.21)	22.2 (0.87)	7.0 (0.28)					M5	#10
EVY1-6C				12.0 (0.47)	6.4 (0.25)	27.9 (1.10)	11.0 (0.43)					M6	1/4
EVY2-3C	Blue	1.5-2.5	16-14	5.8 (0.23)	3.2 (0.13)	21.7 (0.85)	6.5 (0.26)	10.5 (0.41)	5.0 (0.20)	2.3 (0.09)	0.8 (0.03)	M3	#4
EVY2-3.5C				6.4 (0.25)	3.7 (0.15)	21.7 (0.85)	6.5 (0.26)					M3.5	#6
EVY2-4C				7.2 (0.28)	4.3 (0.17)	21.7 (0.85)	6.5 (0.26)					M4	#8
EVY2-5C				9.5 (0.37)	5.3 (0.21)	22.2 (0.87)	7.0 (0.28)					M5	#10
EVY2-6C				12.0 (0.47)	6.4 (0.25)	27.9 (1.10)	11.0 (0.43)					M6	1/4
EVY5-3.5C	Yellow	4-6	12-10	8.3 (0.33)	3.7 (0.15)	26.0 (1.02)	7.5 (0.30)	13.0 (0.51)	6.7 (0.26)	3.4 (0.13)	1.0 (0.04)	M3.5	#6
EVY5-4C				9.5 (0.37)	4.3 (0.17)	25.7 (1.01)	7.5 (0.30)					M4	#8
EVY5-5C				9.5 (0.37)	5.3 (0.21)	25.7 (1.01)	7.5 (0.30)					M5	#10
EVY5-6C				12.0 (0.47)	6.4 (0.25)	31.7 (1.25)	12.0 (0.47)					M6	1/4
EVY5-8C				13.5 (0.53)	8.4 (0.33)	31.7 (1.25)	12.2 (0.48)					M8	5/16

NYLON-INSULATED SPADE TERMINALS (EASY-ENTRY)

- Fork design provides fast and easy installation without removing the fastener
- Insulation support helps to prevent wire damage in bending applications
- Better mechanical strength, high temperature resistance, chemical corrosion resistance and durability
- The design of the easy-entry terminal makes the installation process easier
- Material: Copper tube with tin plated end sleeves with insulation Nylon

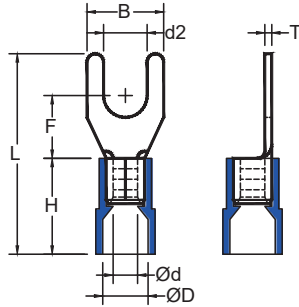

Part No.	Color	Wire Range		Dimension mm (inch)								Stud Size	
		sq. mm.	AWG	B	d2	L	F	H	ØD	Ød	T	mm	inch
ENY1-3	Red	0.5-1.5	22-16	5.8 (0.23)	3.2 (0.13)	22.0 (0.87)	6.3 (0.25)	11.0 (0.43)	4.1 (0.16)	1.7 (0.07)	0.75 (0.03)	M3	#4
ENY1-3.5				6.4 (0.25)	3.7 (0.15)	22.0 (0.87)	6.3 (0.25)					M3.5	#6
ENY1-4				7.2 (0.28)	4.3 (0.17)	22.0 (0.87)	6.3 (0.25)					M4	#8
ENY1-5				9.5 (0.37)	5.3 (0.21)	22.7 (0.89)	7.0 (0.28)					M5	#10
ENY1-6				12.0 (0.47)	6.4 (0.25)	28.4 (1.12)	11.0 (0.43)					M6	1/4
ENY2-3	Blue	1.5-2.5	16-14	5.8 (0.23)	3.2 (0.13)	22.2 (0.87)	6.5 (0.26)	11.0 (0.43)	4.5 (0.18)	2.3 (0.09)	0.8 (0.03)	M3	#4
ENY2-3.5				6.4 (0.25)	3.7 (0.15)	22.2 (0.87)	6.5 (0.26)					M3.5	#6
ENY2-4				7.2 (0.28)	4.3 (0.17)	22.2 (0.87)	6.5 (0.26)					M4	#8
ENY2-5				9.5 (0.37)	5.3 (0.21)	22.7 (0.89)	7.0 (0.28)					M5	#10
ENY2-6				12.0 (0.47)	6.4 (0.25)	28.4 (1.12)	11.0 (0.43)					M6	1/4
ENY5-3.5	Yellow	4-6	12-10	8.3 (0.33)	3.7 (0.15)	26.0 (1.02)	7.5 (0.30)	13.0 (0.51)	6.5 (0.26)	3.4 (0.13)	1.0 (0.04)	M3.5	#6
ENY5-4				9.5 (0.37)	4.3 (0.17)	25.7 (1.01)	7.5 (0.30)					M4	#8
ENY5-5				9.5 (0.37)	5.3 (0.21)	25.7 (1.01)	7.5 (0.30)					M5	#10
ENY5-6				12.0 (0.47)	6.4 (0.25)	31.7 (1.25)	12.0 (0.47)					M6	1/4
ENY5-8				13.5 (0.53)	8.4 (0.33)	31.7 (1.25)	12.2 (0.48)					M8	5/16

NYLON-INSULATED SPADE TERMINALS (DOUBLE CRIMP)

- Fork design provides fast and easy installation without removing the fastener
- Insulation support helps to prevent wire damage in bending applications
- The design of the easy-entry terminal makes the installation process easier
- Provide better conductivity and contact area
- Material: Copper tube with tin plated end sleeves with insulation Nylon

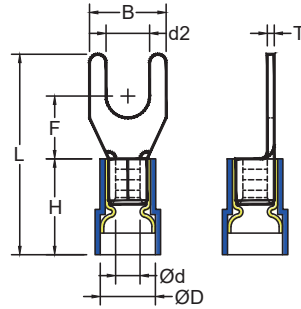

Part No.	Color	Wire Range		Dimension mm (inch)								Stud Size	
		sq. mm.	AWG	B	d2	L	F	H	ØD	Ød	T	mm	inch
ENY1-3C	Red	0.5-1.5	22-16	5.8 (0.23)	3.2 (0.13)	22 (0.87)	6.3 (0.25)	11.0 (0.43)	4.5 (0.18)	1.7 (0.07)	0.75 (0.03)	M3	#4
ENY1-3.5C				6.4 (0.25)	3.7 (0.15)	22.0 (0.87)	6.3 (0.25)					M3.5	#6
ENY1-4C				7.2 (0.28)	4.3 (0.17)	22.0 (0.87)	6.3 (0.25)					M4	#8
ENY1-5C				9.5 (0.37)	5.3 (0.21)	22.7 (0.89)	7.0 (0.28)					M5	#10
ENY1-6C				12 (0.47)	6.4 (0.25)	28.4 (1.12)	11.0 (0.43)					M6	1/4
ENY2-3C	Blue	1.5-2.5	16-14	5.8 (0.23)	3.2 (0.13)	22.2 (0.87)	6.5 (0.26)	11.0 (0.43)	5.0 (0.20)	2.3 (0.09)	0.8 (0.03)	M3	#4
ENY2-3.5C				6.4 (0.25)	3.7 (0.15)	22.2 (0.87)	6.5 (0.26)					M3.5	#6
ENY2-4C				7.2 (0.28)	4.3 (0.17)	22.2 (0.87)	6.5 (0.26)					M4	#8
ENY2-5C				9.5 (0.37)	5.3 (0.21)	22.7 (0.89)	7.0 (0.28)					M5	#10
ENY2-6C				12.0 (0.47)	6.4 (0.25)	28.4 (1.12)	11.0 (0.43)					M6	1/4
ENY5-3.5C	Yellow	4-6	12-10	8.3 (0.33)	3.7 (0.15)	26.0 (1.02)	7.5 (0.30)	13.0 (0.51)	6.7 (0.26)	3.4 (0.13)	1.0 (0.04)	M3.5	#6
ENY5-4C				9.5 (0.37)	4.3 (0.17)	25.7 (1.01)	7.5 (0.30)					M4	#8
ENY5-5C				9.5 (0.37)	5.3 (0.21)	25.7 (1.01)	7.5 (0.30)					M5	#10
ENY5-6C				12.0 (0.47)	6.4 (0.25)	31.7 (1.25)	12.0 (0.47)					M6	1/4
ENY5-8C				13.5 (0.53)	8.4 (0.33)	31.7 (1.25)	12.2 (0.48)					M8	5/16

INSULATED HEAT SHRINKABLE SPADE TERMINALS (BRAZED SEAM)

- Brazed seam protects terminal barrel from splitting during the crimping process
- Fork design provides fast and easy installation without removing the fastener
- Insulation support helps to prevent wire damage in bending applications
- Provides excellent electrical insulation, sealing, waterproof, corrosion resistance and temperature resistance
- Material: Copper tube with tin plated end sleeves with insulation high density PE

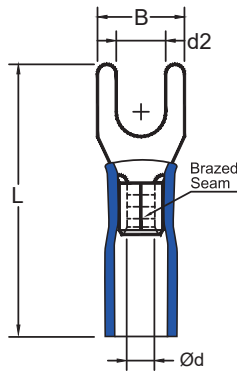

Part No.	Color	Wire Range		Dimension mm (inch)				Stud Size	
		sq. mm.	AWG	B	d2	L	Ød	mm	inch
HY1-3.5B	Red	0.5-1.5	22-16	6.4 (0.25)	3.7 (0.15)	28.0 (1.10)	1.7 (0.07)	M3.5	#6
HY1-4B				7.2 (0.28)	4.3 (0.17)	28.0 (1.10)		M4	#8
HY1-5B				9.5 (0.37)	5.3 (0.21)	29.0 (1.14)		M5	#10
HY2-3.5B	Blue	1.5-2.5	16-14	6.4 (0.25)	3.7 (0.15)	28.0 (1.10)	2.3 (0.09)	M3.5	#6
HY2-4B				7.2 (0.28)	4.3 (0.17)	28.0 (1.10)		M4	#8
HY2-5B				9.5 (0.37)	5.3 (0.21)	29.0 (1.14)		M5	#10
HY5-4B	Yellow	4-6	12-10	9.5 (0.37)	4.3 (0.17)	33.0 (1.30)	3.4 (0.13)	M4	#8
HY5-5B				9.5 (0.37)	5.3 (0.21)	33.0 (1.30)		M5	#10
HY5-6B				12.0 (0.47)	6.4 (0.25)	39.0 (1.54)		M6	1/4

NON-INSULATED BLADE TERMINALS

- Flat blade design to prevent damage to the wire from over tightening, resulting in a reliable electrical connection
- For use with blade-type terminal blocks
- Brazed seam protects terminal barrel from splitting during the crimping process
- Material: Copper

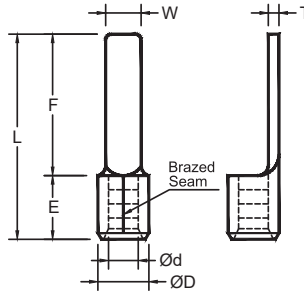

Part No.	Wire Range		Dimension mm (inch)						
	sq. mm.	AWG	W	L	F	E	Ød	ØD	T
B1-9B	0.5-1.5	22-16	2.8 (0.11)	14.0 (0.55)	9.0 (0.35)	5.0 (0.20)	1.7 (0.07)	3.4 (0.13)	0.75 (0.03)
B1-12B			3.0 (0.12)	16.1 (0.63)	11.1 (0.44)				
B1-14.5B			3.0 (0.12)	19.5 (0.77)	14.5 (0.57)				
B1-18B			2.3 (0.09)	23.0 (0.91)	18.0 (0.71)				
B2-9B	1.5-2.5	16-14	2.8 (0.11)	14.0 (0.55)	9.0 (0.35)	5.0 (0.20)	2.3 (0.09)	4.1 (0.16)	0.8 (0.03)
B2-18B			2.2 (0.09)	23.2 (0.91)	18.2 (0.72)				
B5-10B	4-6	12-10	2.8 (0.11)	16.0 (0.63)	10.0 (0.39)	6.0 (0.24)	3.4 (0.13)	5.6 (0.22)	1.0 (0.04)
B5-13B			4.5 (0.18)	20.0 (0.79)	14.0 (0.55)				
B5-18B			4.5 (0.18)	24.2 (0.95)	18.2 (0.72)				

VINYL-INSULATED BLADE TERMINALS

- Flat blade design to prevent damage to the wire from over tightening, resulting in a reliable electrical connection
- For use with blade-type terminal blocks
- Insulation support helps to prevent wire damage in bending applications
- Material: Copper tube with tin plated end sleeves with insulation PVC

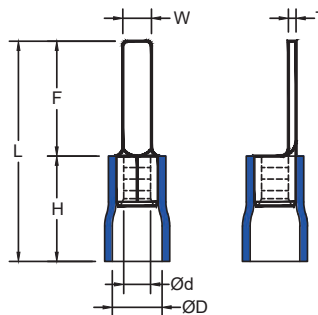

Part No.	Color	Wire Range		Dimension mm (inch)						
		sq. mm.	AWG	W	L	F	H	Ød	ØD	T
VB1-9	Red	0.5-1.5	22-16	2.8 (0.11)	19.0 (0.75)	9.0 (0.35)	10.5 (0.41)	1.7 (0.07)	4.2 (0.17)	0.75 (0.03)
VB1-14.5				3.0 (0.12)	24.5 (0.96)	14.5 (0.57)				
VB1-18				2.3 (0.09)	28.0 (1.10)	18.0 (0.71)				
VB2-9	Blue	1.5-2.5	16-14	2.8 (0.11)	19.0 (0.75)	9.0 (0.35)	11.0 (0.43)	2.3 (0.09)	4.6 (0.18)	0.8 (0.03)
VB2-18				2.2 (0.09)	28.2 (1.11)	18.2 (0.72)				
VB5-10	Yellow	4-6	12-10	2.8 (0.11)	23.0 (0.91)	10.0 (0.39)	13.0 (0.51)	3.4 (0.13)	6.6 (0.26)	1.0 (0.04)
VB5-13				4.5 (0.18)	27.2 (1.07)	14.2 (0.56)				
VB5-18				4.5 (0.18)	31.2 (1.23)	18.2 (0.72)				

VINYL-INSULATED BLADE TERMINALS (EASY-ENTRY)

- Flat blade design to prevent damage to the wire from over tightening, resulting in a reliable electrical connection
- Insulation support helps to prevent wire damage in bending applications
- Material: Copper tube with tin plated end sleeves with insulation PVC

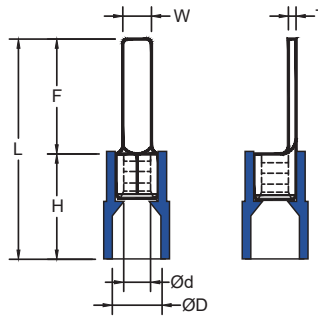

Part No.	Color	Wire Range		Dimension mm (inch)						
		sq. mm.	AWG	W	L	F	H	Ød	ØD	T
EVB1-9	Red	0.5-1.5	22-16	2.8 (0.11)	19.5 (0.77)	9.0 (0.35)	10.5 (0.41)	1.7 (0.07)	4.1 (0.16)	0.75 (0.03)
EVB1-10				2.3 (0.09)	20.7 (0.81)	10.2 (0.40)				
EVB1-11				3.0 (0.12)	21.6 (0.85)	11.1 (0.44)				
EVB1-14				3.0 (0.12)	25.0 (0.98)	14.5 (0.57)				
EVB1-18				2.3 (0.09)	28.5 (1.12)	18.0 (0.71)				
EVB2-9	Blue	1.5-2.5	16-14	2.8 (0.11)	20.0 (0.79)	9.0 (0.35)	11.0 (0.43)	2.3 (0.09)	4.5 (0.18)	0.8 (0.03)
EVB2-10				2.2 (0.09)	21.0 (0.83)	10.0 (0.39)				
EVB2-13				2.2 (0.09)	24.0 (0.94)	13.0 (0.51)				
EVB2-18				2.2 (0.09)	29.2 (1.15)	18.2 (0.72)				
EVB5-10	Yellow	4-6	12-10	2.8 (0.11)	23.0 (0.91)	10.0 (0.39)	13.0 (0.51)	3.4 (0.13)	6.5 (0.26)	1.0 (0.04)
EVB5-14				4.5 (0.18)	27.2 (1.07)	14.2 (0.56)				
EVB5-18				4.5 (0.18)	31.2 (1.23)	18.2 (0.72)				

VINYL-INSULATED BLADE TERMINALS (DOUBLE CRIMP)

- Flat blade design to prevent damage to the wire from over tightening, resulting in a reliable electrical connection
- Insulation support helps to prevent wire damage in bending applications
- The design of the easy-entry terminal makes the installation process easier
- Provide better conductivity and contact area
- Material: Copper tube with tin plated end sleeves with insulation PVC

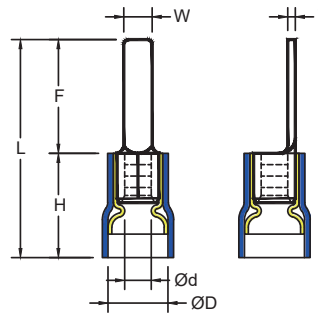

Part No.	Color	Wire Range		Dimension mm (inch)						
		sq. mm.	AWG	W	L	F	H	Ød	ØD	T
EVB1-9C	Red	0.5-1.5	22-16	2.8 (0.11)	19.5 (0.77)	9.0 (0.35)	10.5 (0.41)	1.7 (0.07)	4.5 (0.18)	0.75 (0.03)
EVB1-10C				2.3 (0.09)	20.7 (0.81)	10.2 (0.40)				
EVB1-11C				3.0 (0.12)	21.6 (0.85)	11.1 (0.44)				
EVB1-14C				3.0 (0.12)	25.0 (0.98)	14.5 (0.57)				
EVB1-18C				2.3 (0.09)	28.5 (1.12)	18.0 (0.71)				
EVB2-9C	Blue	1.5-2.5	16-14	2.8 (0.11)	19.5 (0.77)	9.0 (0.35)	10.5 (0.41)	2.3 (0.09)	5.0 (0.20)	0.8 (0.03)
EVB2-10C				2.2 (0.09)	20.5 (0.81)	10.0 (0.39)				
EVB2-13C				2.2 (0.09)	23.5 (0.93)	13.0 (0.51)				
EVB2-18C				2.2 (0.09)	28.7 (1.13)	18.2 (0.72)				
EVB5-10C	Yellow	4-6	12-10	2.8 (0.11)	23.0 (0.91)	10.0 (0.39)	13.0 (0.51)	3.4 (0.13)	6.7 (0.26)	1.0 (0.04)
EVB5-14C				4.5 (0.18)	27.2 (1.07)	14.2 (0.56)				
EVB5-18C				4.5 (0.18)	31.2 (1.23)	18.2 (0.72)				

NYLON-INSULATED BLADE TERMINALS (EASY-ENTRY)

- Flat blade design to prevent damage to the wire from over tightening, resulting in a reliable electrical connection
- Insulation support helps to prevent wire damage in bending applications
- Better mechanical strength, high temperature resistance, chemical corrosion resistance and durability
- The design of the easy-entry terminal makes the installation process easier
- Material: Copper tube with tin plated end sleeves with insulation Nylon

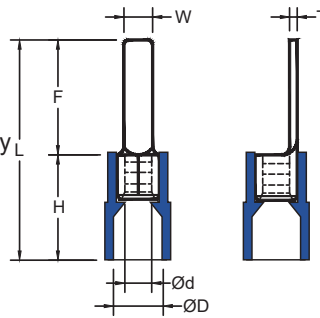

Part No.	Color	Wire Range		Dimension mm (inch)						
		sq. mm.	AWG	W	L	F	H	Ød	ØD	T
ENB1-9	Red	0.5-1.5	22-16	2.8 (0.11)	20.0 (0.79)	9.0 (0.35)	11.0 (0.43)	1.7 (0.07)	4.1 (0.16)	0.75 (0.03)
ENB1-10				2.3 (0.09)	21.2 (0.83)	10.2 (0.40)				
ENB1-11				3.0 (0.12)	22.1 (0.87)	11.1 (0.44)				
ENB1-14				3.0 (0.12)	25.5 (1.00)	14.5 (0.57)				
ENB1-18				2.3 (0.09)	29.0 (1.14)	18.0 (0.71)				
ENB2-9	Blue	1.5-2.5	16-14	2.8 (0.11)	20.0 (0.79)	9.0 (0.35)	11.0 (0.43)	2.3 (0.09)	4.5 (0.18)	0.8 (0.03)
ENB2-10				2.2 (0.09)	21.0 (0.83)	10.0 (0.39)				
ENB2-13				2.2 (0.09)	24.0 (0.94)	13.0 (0.51)				
ENB2-18				2.2 (0.09)	29.2 (1.15)	18.2 (0.72)				
ENB5-10	Yellow	4-6	12-10	2.8 (0.11)	23.0 (0.91)	10.0 (0.39)	13.0 (0.51)	3.4 (0.13)	6.5 (0.26)	1.0 (0.04)
ENB5-14				4.5 (0.18)	27.2 (1.07)	14.2 (0.56)				
ENB5-18				4.5 (0.18)	31.2 (1.23)	18.2 (0.72)				

NYLON-INSULATED BLADE TERMINALS (DOUBLE CRIMP)

- Flat blade design to prevent damage to the wire from over tightening, resulting in a reliable electrical connection
- Insulation support helps to prevent wire damage in bending applications
- Better mechanical strength, high temperature resistance, chemical corrosion resistance and durability
- The design of the easy-entry terminal makes the installation process easier
- Provide better conductivity and contact area
- Material: Copper tube with tin plated end sleeves with insulation Nylon

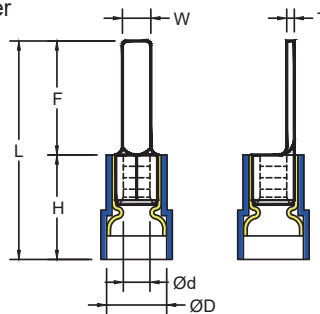

Part No.	Color	Wire Range		Dimension mm (inch)						
		sq. mm.	AWG	W	L	F	H	Ød	ØD	T
ENB1-9C	Red	0.5-1.5	22-16	2.8 (0.11)	20.0 (0.79)	9.0 (0.35)	11.0 (0.43)	1.7 (0.07)	4.5 (0.18)	0.75 (0.03)
ENB1-10C				2.3 (0.09)	21.2 (0.83)	10.2 (0.40)				
ENB1-11C				3.0 (0.12)	22.1 (0.87)	11.1 (0.44)				
ENB1-14C				3.0 (0.12)	25.4 (1.00)	14.5 (0.57)				
ENB1-18C				2.3 (0.09)	29.0 (1.14)	18.0 (0.71)				
ENB2-9C	Blue	1.5-2.5	16-14	2.8 (0.11)	20.0 (0.79)	9.0 (0.35)	11.0 (0.43)	2.3 (0.09)	5.0 (0.20)	0.8 (0.03)
ENB2-10C				2.2 (0.09)	21.0 (0.83)	10.0 (0.39)				
ENB2-13C				2.2 (0.09)	24.0 (0.94)	13.0 (0.51)				
ENB2-18C				2.2 (0.09)	29.2 (1.15)	18.2 (0.72)				
ENB5-10C	Yellow	4-6	12-10	2.8 (0.11)	23.0 (0.91)	10.0 (0.39)	13.0 (0.51)	3.4 (0.13)	6.7 (0.26)	1.0 (0.04)
ENB5-14C				4.5 (0.18)	27.0 (1.06)	14.2 (0.56)				
ENB5-18C				4.5 (0.18)	31.2 (1.23)	18.2 (0.72)				

NON-INSULATED PIN TERMINALS

- Solid pin designed to prevent damage to the wire from over tightening, resulting in a reliable electrical connection
- Brazed seam protects terminal barrel from splitting during the crimping process
- Material: Copper

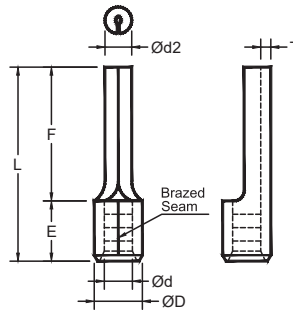

Part No.	Wire Range		Dimension mm (inch)						
	sq. mm.	AWG	Ød2	L	F	E	Ød	ØD	T
P1-9B	0.5-1.5	22-16	1.9 (0.07)	15.0 (0.59)	10.0 (0.39)	5.0 (0.20)	1.7 (0.07)	3.4 (0.13)	0.75 (0.03)
P1-12B			1.9 (0.07)	17.0 (0.67)	12.0 (0.47)	5.0 (0.20)			
P2-9B	1.5-2.5	16-14	1.9 (0.07)	15.0 (0.59)	10.0 (0.39)	5.0 (0.20)	2.3 (0.09)	4.1 (0.16)	0.8 (0.03)
P2-12B			1.9 (0.07)	17.0 (0.67)	12.0 (0.47)	5.0 (0.20)			
P5-13.5B	4-6	12-10	2.7 (0.11)	20.0 (0.79)	14.0 (0.55)	6.0 (0.24)	3.4 (0.13)	5.6 (0.22)	1.0 (0.04)

VINYL-INSULATED PIN TERMINALS

- Solid pin designed to prevent damage to the wire from over tightening, resulting in a reliable electrical connection
- Insulation support helps to prevent wire damage in bending applications
- Material: Copper tube with tin plated end sleeves with insulation PVC

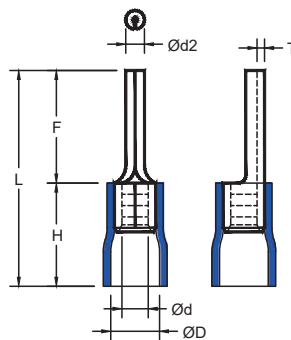

Part No.	Color	Wire Range		Dimension mm (inch)						
		sq. mm.	AWG	Ød2	L	F	H	Ød	ØD	T
VP1-9	Red	0.5-1.5	22-16	1.9 (0.07)	20.0 (0.79)	10.0 (0.39)	10.0 (0.39)	1.7 (0.07)	4.2 (0.17)	0.75 (0.03)
VP1-12				1.9 (0.07)	22.0 (0.87)	12.0 (0.47)				
VP2-9	Blue	1.5-2.5	16-14	1.9 (0.07)	20.0 (0.79)	10.0 (0.39)	10.0 (0.39)	2.3 (0.09)	4.6 (0.18)	0.8 (0.03)
VP2-12				1.9 (0.07)	22.0 (0.87)	12.0 (0.47)				
VP5-13.5	Yellow	4-6	12-10	2.7 (0.11)	27.0 (1.06)	14.0 (0.55)	13.0 (0.51)	3.4 (0.13)	6.6 (0.26)	1.0 (0.04)

VINYL-INSULATED PIN TERMINALS (EASY-ENTRY)

- Solid pin designed to prevent damage to the wire from over tightening, resulting in a reliable electrical connection
- Insulation support helps to prevent wire damage in bending applications
- The design of the easy-entry terminal makes the installation process easier
- Material: Copper tube with tin plated end sleeves with insulation PVC

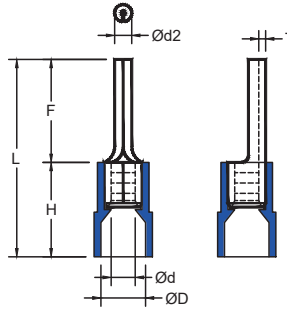

Part No.	Color	Wire Range		Dimension mm (inch)						
		sq. mm.	AWG	Ød2	L	F	H	Ød	ØD	T
EVP1-9	Red	0.5-1.5	22-16	1.9 (0.07)	20.5 (0.81)	10.0 (0.39)	10.5 (0.41)	1.7 (0.07)	4.1 (0.16)	0.75 (0.03)
EVP1-12				1.9 (0.07)	22.5 (0.89)	12.0 (0.47)				
EVP2-9	Blue	1.5-2.5	16-14	1.9 (0.07)	21.0 (0.83)	10.0 (0.39)	11.0 (0.43)	2.3 (0.09)	4.5 (0.18)	0.8 (0.03)
EVP2-12				1.9 (0.07)	23.0 (0.91)	12.0 (0.47)				
EVP5-13.5	Yellow	4-6	12-10	2.7 (0.11)	27.0 (1.06)	14.0 (0.55)	13.0 (0.51)	3.4 (0.13)	6.5 (0.26)	1.0 (0.04)

VINYL-INSULATED PIN TERMINALS (DOUBLE CRIMP)

- Solid pin designed to prevent damage to the wire from over tightening, resulting in a reliable electrical connection
- Insulation support helps to prevent wire damage in bending applications
- The design of the easy-entry terminal makes the installation process easier
- Provide better conductivity and contact area
- Material: Copper tube with tin plated end sleeves with insulation PVC

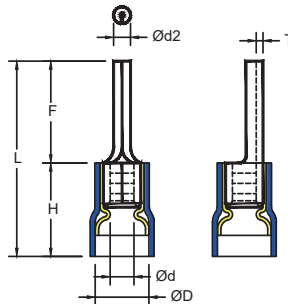

Part No.	Color	Wire Range		Dimension mm (inch)						
		sq. mm.	AWG	Ød2	L	F	H	Ød	ØD	T
EVP1-9C	Red	0.5-1.5	22-16	1.9 (0.07)	20.5 (0.81)	10.0 (0.39)	10.5 (0.41)	1.7 (0.07)	4.5 (0.18)	0.75 (0.03)
EVP1-12C				1.9 (0.07)	22.5 (0.89)	12.0 (0.47)				
EVP2-9C	Blue	1.5-2.5	16-14	1.9 (0.07)	20.5 (0.81)	10.0 (0.39)	10.5 (0.41)	2.3 (0.09)	5.0 (0.20)	0.8 (0.03)
EVP2-12C				1.9 (0.07)	22.5 (0.89)	12.0 (0.47)				
EVP5-13.5C	Yellow	4-6	12-10	2.7 (0.11)	27.0 (1.06)	14.0 (0.55)	13.0 (0.51)	3.4 (0.13)	6.7 (0.26)	1.0 (0.04)

NYLON-INSULATED PIN TERMINALS (EASY-ENTRY)

- Solid pin designed to prevent damage to the wire from over tightening, resulting in a reliable electrical connection
- Insulation support helps to prevent wire damage in bending applications
- Better mechanical strength, high temperature resistance, chemical corrosion resistance and durability
- The design of the easy-entry terminal makes the installation process easier
- Material: Copper tube with tin plated end sleeves with insulation Nylon

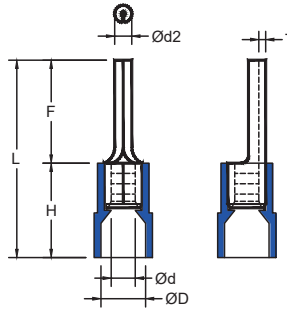

Part No.	Color	Wire Range		Dimension mm (inch)						
		sq. mm.	AWG	Ød2	L	F	H	Ød	ØD	T
ENP1-9	Red	0.5-1.5	22-16	1.9 (0.07)	21.0 (0.83)	10.0 (0.39)	10.5 (0.41)	1.7 (0.07)	4.1 (0.16)	0.75 (0.03)
ENP1-12				1.9 (0.07)	23.0 (0.91)	12.0 (0.47)				
ENP2-9	Blue	1.5-2.5	16-14	1.9 (0.07)	21.0 (0.83)	10.0 (0.39)	11.0 (0.43)	2.3 (0.09)	4.5 (0.18)	0.8 (0.03)
ENP2-12				1.9 (0.07)	23.0 (0.91)	12.0 (0.47)				
ENP5-13.5	Yellow	4-6	12-10	2.7 (0.11)	27.0 (1.06)	14.0 (0.55)	13.0 (0.51)	3.4 (0.13)	6.5 (0.26)	1.0 (0.04)

NYLON-INSULATED PIN TERMINALS (DOUBLE CRIMP)

- Solid pin designed to prevent damage to the wire from over tightening, resulting in a reliable electrical connection
- Insulation support helps to prevent wire damage in bending applications
- Better mechanical strength, high temperature resistance, chemical corrosion resistance and durability
- The design of the easy-entry terminal makes the installation process easier
- Provide better conductivity and contact area
- Material: Copper tube with tin plated end sleeves with insulation Nylon

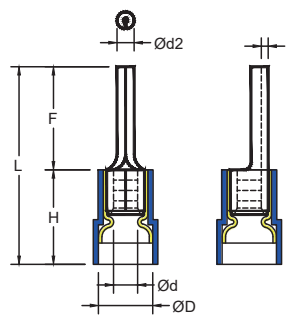

Part No.	Color	Wire Range		Dimension mm (inch)						
		sq. mm.	AWG	Ød2	L	F	H	Ød	ØD	T
ENP1-9C	Red	0.5-1.5	22-16	1.9 (0.07)	21.0 (0.83)	10.0 (0.39)	11.0 (0.43)	1.7 (0.07)	4.5 (0.18)	0.75 (0.03)
ENP1-12C				1.9 (0.07)	23.0 (0.91)	12.0 (0.47)				
ENP2-9C	Blue	1.5-2.5	16-14	1.9 (0.07)	21.0 (0.83)	10.0 (0.39)	11.0 (0.43)	2.3 (0.09)	5.0 (0.20)	0.8 (0.03)
ENP2-12C				1.9 (0.07)	23.0 (0.91)	12.0 (0.47)				
ENP5-13.5C	Yellow	4-6	12-10	2.7 (0.11)	27.0 (1.06)	14.0 (0.55)	13.0 (0.51)	3.4 (0.13)	6.7 (0.26)	1.0 (0.04)

VINYL-INSULATED FEMALE DISCONNECTORS

- Disconnect can be inserted and removed from the male tab without the use of tools for lower installation cost
- Metal insulation grip sleeve crimps to wire insulation, providing protection to the crimp joint during high vibration applications
- Internal wire stop assures proper length of insertion into terminal barrel, providing a higher quality connection
- Material: Brass, PVC

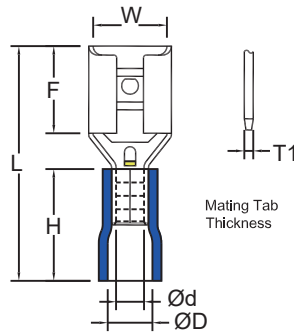

Part No.	Color	Wire Range		Dimension mm (inch)						
		sq. mm.	AWG	W	L	F	H	Ød	ØD	T1
VF1-2.8	Red	0.5-1.5	22-16	3.2 (0.13)	18.4 (0.72)	6.4 (0.25)	10.0 (0.39)	1.7 (0.07)	4.0 (0.16)	0.8 (0.03)
VF1-4.8				5.0 (0.20)	19.0 (0.75)	6.4 (0.25)				0.8 (0.03)
VF1-5.2				5.7 (0.22)	19.0 (0.75)	5.9 (0.23)				0.5 (0.02)
VF1-6.3				6.6 (0.26)	21.0 (0.83)	7.8 (0.31)				0.8 (0.03)
VF2-2.8	Blue	1.5-2.5	16-14	3.2 (0.13)	18.4 (0.72)	6.4 (0.25)	10.0 (0.39)	2.3 (0.09)	4.5 (0.18)	0.8 (0.03)
VF2-4.8				5.0 (0.20)	19.0 (0.75)	6.4 (0.25)				0.8 (0.03)
VF2-5.2				5.7 (0.22)	19.0 (0.75)	5.9 (0.23)				0.5 (0.02)
VF2-6.3				6.6 (0.26)	21.0 (0.83)	7.8 (0.31)				0.8 (0.03)
VF5-6.3	Yellow	4-6	12-10	6.6 (0.26)	24.0 (0.94)	7.8 (0.31)	13.0 (0.51)	3.4 (0.13)	5.5 (0.22)	0.8 (0.03)
VF5-9.5				10.0 (0.39)	29.0 (1.14)	12.0 (0.47)				1.2 (0.05)

VINYL-INSULATED FEMALE DISCONNECTORS (DOUBLE CRIMP)

- Disconnect can be inserted and removed from the male tab without the use of tools for lower installation cost
- Metal insulation grip sleeve crimps to wire insulation, providing protection to the crimp joint during high vibration applications.
- Internal wire stop assures proper length of insertion into terminal barrel, providing a higher quality connection
- The design of the easy-entry terminal makes the installation process easier
- Provide better conductivity and contact area
- Material: Brass, PVC

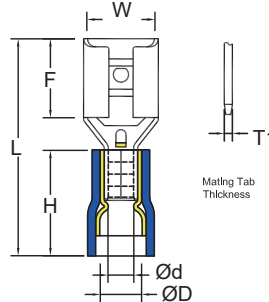

Part No.	Color	Wire Range		Dimension mm (inch)						
		sq. mm.	AWG	W	L	F	H	Ød	ØD	T1
EVF1-2.8C	Red	0.5-1.5	22-16	3.2 (0.13)	18.9 (0.74)	6.4 (0.25)	10.5 (0.41)	1.7 (0.07)	4.1 (0.16)	0.8 (0.03)
EVF1-4.8C				5.0 (0.20)	19.5 (0.77)	6.4 (0.25)				
EVF1-5.2C				5.7 (0.22)	19.5 (0.77)	5.9 (0.23)				
EVF1-6.3C				6.6 (0.26)	21.5 (0.85)	7.8 (0.31)				
EVF2-2.8C	Blue	1.5-2.5	16-14	3.2 (0.13)	18.9 (0.74)	6.4 (0.25)	10.5 (0.41)	2.3 (0.09)	4.9 (0.19)	0.8 (0.03)
EVF2-4.8C				5.0 (0.20)	19.5 (0.77)	6.4 (0.25)				
EVF2-5.2C				5.7 (0.22)	19.5 (0.77)	5.9 (0.23)				
EVF2-6.3C				6.6 (0.26)	21.5 (0.85)	7.8 (0.31)				
EVF5-2.8C	Yellow	4-6	12-10	3.2 (0.13)	21.4 (0.84)	6.4 (0.25)	13.0 (0.51)	3.4 (0.13)	6.7 (0.26)	0.8 (0.03)
EVF5-4.8C				5.0 (0.20)	22.0 (0.87)	6.4 (0.25)				
EVF5-6.3C				6.6 (0.26)	24.0 (0.94)	7.8 (0.31)				

NYLON- INSULATED FEMALE DISCONNECTORS(EASY ENTRY)

- Disconnect can be inserted and removed from the male tab without the use of tools for lower installation cost
- Better mechanical strength, high temperature resistance, chemical corrosion resistance and durability
- Metal insulation grip sleeve crimps to wire insulation, providing protection to the crimp joint during high vibration applications.
- Internal wire stop assures proper length of insertion into terminal barrel, providing a higher quality connection
- The design of the easy-entry terminal makes the installation process easier
- Material: Brass, Nylon

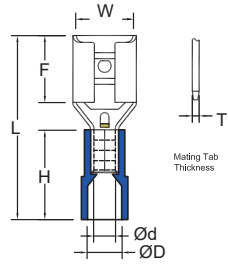

Part No.	Color	Wire Range		Dimension mm (inch)						
		sq. mm.	AWG	W	L	F	H	Ød	ØD	T1
ENF1-2.8	Red	0.5-1.5	22-16	3.2 (0.13)	19.4 (0.76)	6.4 (0.25)	11.0 (0.43)	1.7 (0.07)	4.1 (0.16)	0.8 (0.03)
ENF1-4.8				5.0 (0.20)	20.0 (0.79)	6.4 (0.25)				
ENF1-5.2				5.7 (0.22)	20.0 (0.79)	5.9 (0.23)				
ENF1-6.3				6.6 (0.26)	22.0 (0.87)	7.8 (0.31)				
ENF1-8				8.2 (0.32)	24.0 (0.94)	10.0 (0.39)				
ENF2-2.8	Blue	1.5-2.5	16-14	3.2 (0.13)	19.4 (0.76)	6.4 (0.25)	11.0 (0.43)	2.3 (0.09)	4.5 (0.18)	0.8 (0.03)
ENF2-4.8				5.0 (0.20)	20.0 (0.79)	6.4 (0.25)				
ENF2-5.2				5.7 (0.22)	20.0 (0.79)	5.9 (0.23)				
ENF2-6.3				6.6 (0.26)	22.0 (0.87)	7.8 (0.31)				
ENF2-8				8.2 (0.32)	24.0 (0.94)	10.0 (0.39)				
ENF5-6.3	Yellow	4-6	12-10	6.6 (0.26)	24.0 (0.94)	7.8 (0.31)	13.0 (0.51)	3.4 (0.13)	6.5 (0.26)	0.8 (0.03)
ENF5-9.5				10.0 (0.39)	29.0 (1.14)	12.0 (0.47)				1.2 (0.05)

NYLON-INSULATED FEMALE DISCONNECTORS (DOUBLE CRIMP)

- Disconnect can be inserted and removed from the male tab without the use of tools for lower installation cost
- Better mechanical strength, high temperature resistance, chemical corrosion resistance and durability
- Metal insulation grip sleeve crimps to wire insulation, providing protection to the crimp joint during high vibration applications.
- Internal wire stop assures proper length of insertion into terminal barrel, providing a higher quality connection
- The design of the easy-entry terminal makes the installation process easier
- Provide better conductivity and contact area
- Material: Brass, Nylon

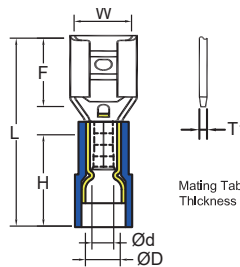

Part No.	Color	Wire Range		Dimension mm (inch)						
		sq. mm.	AWG	W	L	F	H	Ød	ØD	T1
ENF1-2.8C	Red	0.5-1.5	22-16	3.2 (0.13)	19.4 (0.76)	6.4 (0.25)	11.0 (0.43)	1.7 (0.07)	4.1 (0.16)	0.8 (0.03)
ENF1-4.8C				5.0 (0.20)	20.0 (0.79)	6.4 (0.25)				
ENF1-5.2C				5.7 (0.22)	20.0 (0.79)	5.9 (0.23)				
ENF1-6.3C				6.6 (0.26)	22.0 (0.87)	7.8 (0.31)				
ENF1-8C				8.2 (0.32)	24.0 (0.94)	10.0 (0.39)				
ENF2-2.8C	Blue	1.5-2.5	16-14	3.2 (0.13)	19.4 (0.76)	6.4 (0.25)	11.0 (0.43)	2.3 (0.09)	4.9 (0.19)	0.8 (0.03)
ENF2-4.8C				5.0 (0.20)	20.0 (0.79)	6.4 (0.25)				
ENF2-5.2C				5.7 (0.22)	20.0 (0.79)	5.9 (0.23)				
ENF2-6.3C				6.6 (0.26)	22.0 (0.87)	7.8 (0.31)				
ENF2-8C				8.2 (0.32)	24.0 (0.94)	10.0 (0.39)				
ENF5-6.3C	Yellow	4-6	12-10	6.6 (0.26)	24.0 (0.94)	7.8 (0.31)	13.0 (0.51)	3.4 (0.13)	6.7 (0.26)	0.8 (0.03)
ENF5-9.5C				10.0 (0.39)	29.0 (1.14)	12.0 (0.47)				1.2 (0.05)

VINYL-INSULATED MALE DISCONNECTORS

- Male tab couples with female disconnects
- Male tab can be inserted and removed from the female disconnect without the use of tools for lower installation cost
- Metal insulation grip sleeve crimps to wire insulation, providing protection to the crimp joint during high vibration applications
- Material: Brass, PVC

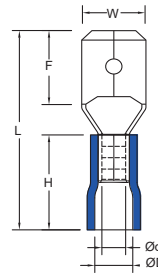

Part No.	Color	Wire Range		Dimension mm (inch)					
		sq. mm.	AWG	W	L	F	H	Ød	ØD
VM1-2.8	Red	0.5-1.5	22-16	2.8 (0.11)	18.8 (0.74)	6.6 (0.26)	10.0 (0.39)	1.7 (0.07)	4.0 (0.16)
VM1-4.8				4.8 (0.19)	18.8 (0.74)	6.6 (0.26)			
VM1-6.3				6.3 (0.25)	21.0 (0.83)	7.8 (0.31)			
VM2-2.8	Blue	1.5-2.5	16-14	2.8 (0.11)	18.8 (0.74)	6.6 (0.26)	10.0 (0.39)	2.3 (0.09)	4.5 (0.18)
VM2-4.8				4.8 (0.19)	18.8 (0.74)	6.6 (0.26)			
VM2-6.3				6.3 (0.25)	21.0 (0.83)	7.8 (0.31)			
VM5-6.3	Yellow	4-6	12-10	6.3 (0.25)	24.0 (0.94)	7.8 (0.31)	13.0 (0.51)	3.4 (0.13)	5.5 (0.22)

VINYL-INSULATED MALE DISCONNECTORS (DOUBLE CRIMP)

- Male tab can be inserted and removed from the female disconnect without the use of tools for lower installation cost
- Metal insulation grip sleeve crimps to wire insulation, providing protection to the crimp joint during high vibration applications.
- The design of the easy-entry terminal makes the installation process easier
- Provide better conductivity and contact area
- Material: Brass, PVC

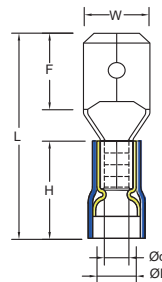

Part No.	Color	Wire Range		Dimension mm (inch)					
		sq. mm.	AWG	W	L	F	H	Ød	ØD
EVM1-2.8C	Red	0.5-1.5	22-16	2.8 (0.11)	19.3 (0.76)	6.6 (0.26)	10.5 (0.41)	1.7 (0.07)	4.1 (0.16)
EVM1-4.8C				4.8 (0.19)	19.3 (0.76)	6.6 (0.26)			
EVM1-6.3C				6.3 (0.25)	21.5 (0.85)	7.8 (0.31)			
EVM2-2.8C	Blue	1.5-2.5	16-14	2.8 (0.11)	19.3 (0.76)	6.6 (0.26)	10.5 (0.41)	2.3 (0.09)	4.9 (0.19)
EVM2-4.8C				4.8 (0.19)	19.3 (0.76)	6.6 (0.26)			
EVM2-6.3C				6.3 (0.25)	21.5 (0.85)	7.8 (0.31)			
EVM5-6.3C	Yellow	4-6	12-10	6.3 (0.25)	24.0 (0.94)	7.8 (0.31)	13.0 (0.51)	3.4 (0.13)	6.7 (0.26)

NYLON-INSULATED MALE DISCONNECTORS (EASY-ENTRY)

- Male tab can be inserted and removed from the female disconnect without the use of tools for lower installation cost
- Better mechanical strength, high temperature resistance, chemical corrosion resistance and durability
- Metal insulation grip sleeve crimps to wire insulation, providing protection to the crimp joint during high vibration applications.
- The design of the easy-entry terminal makes the installation process easier
- Material: Brass, Nylon

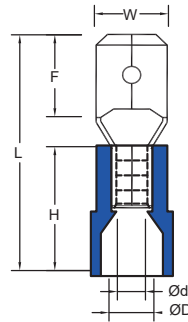

Part No.	Color	Wire Range		Dimension mm (inch)					
		sq. mm.	AWG	W	L	F	H	Ød	ØD
ENM1-2.8	Red	0.5-1.5	22-16	2.8 (0.11)	19.8 (0.78)	6.6 (0.26)	11.0 (0.43)	1.7 (0.07)	4.1 (0.16)
ENM1-4.8				4.8 (0.19)	19.8 (0.78)	6.6 (0.26)			
ENM1-6.3				6.3 (0.25)	22.0 (0.87)	7.8 (0.31)			
ENM2-2.8	Blue	1.5-2.5	16-14	2.8 (0.11)	19.8 (0.78)	6.6 (0.26)	11.0 (0.43)	2.3 (0.09)	4.5 (0.18)
ENM2-4.8				4.8 (0.19)	19.8 (0.78)	6.6 (0.26)			
ENM2-6.3				6.3 (0.25)	22.0 (0.87)	7.8 (0.31)			
ENM5-6.3	Yellow	4-6	12-10	6.3 (0.25)	24.0 (0.94)	7.8 (0.31)	13.0 (0.51)	3.4 (0.13)	6.5 (0.26)

NYLON-INSULATED MALE DISCONNECTORS (DOUBLE CRIMP)

- Male tab can be inserted and removed from the female disconnect without the use of tools for lower installation cost
- Better mechanical strength, high temperature resistance, chemical corrosion resistance and durability
- Metal insulation grip sleeve crimps to wire insulation, providing protection to the crimp joint during high vibration applications.
- The design of the easy-entry terminal makes the installation process easier
- Provide better conductivity and contact area
- Material: Brass, Nylon

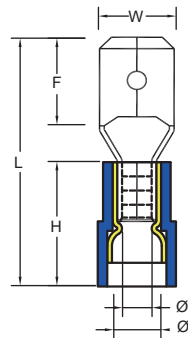

Part No.	Color	Wire Range		Dimension mm (inch)					
		sq. mm.	AWG	W	L	F	H	Ød	ØD
ENM1-2.8C	Red	0.5-1.5	22-16	2.8 (0.11)	19.8 (0.78)	6.6 (0.26)	11.0 (0.43)	1.7 (0.07)	4.1 (0.16)
ENM1-4.8C				4.8 (0.19)	19.8 (0.78)	6.6 (0.26)			
ENM1-6.3C				6.3 (0.25)	22.0 (0.87)	7.8 (0.31)			
ENM2-2.8C	Blue	1.5-2.5	16-14	2.8 (0.11)	19.8 (0.78)	6.6 (0.26)	11.0 (0.43)	2.3 (0.09)	5.0 (0.20)
ENM2-4.8C				4.8 (0.19)	19.8 (0.78)	6.6 (0.26)			
ENM2-6.3C				6.3 (0.25)	22.0 (0.87)	7.8 (0.31)			
ENM5-6.3C	Yellow	4-6	12-10	6.3 (0.25)	24.0 (0.94)	7.8 (0.31)	13.0 (0.51)	3.4 (0.13)	6.5 (0.26)

VINYL-FULLY INSULATED FEMALE DISCONNECTORS

- Disconnect can be inserted and removed from the male tab without the use of tools for lower installation cost
- Fully insulated design provides protection from electrical shorts
- Internal wire stop assures proper length of insertion into terminal barrel, providing a higher quality connection
- Material: Brass, PVC

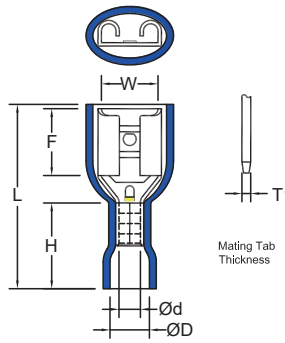

Part No.	Color	Wire Range		Dimension mm (inch)						
		sq. mm.	AWG	W	L	F	H	Ød	ØD	T1
FVF1-4.8	Red	0.5-1.5	22-16	5.0 (0.20)	20.0 (0.79)	6.4 (0.25)	10.5 (0.41)	1.7 (0.07)	4.0 (0.16)	0.8 (0.03)
FVF1-6.3				6.6 (0.26)	22.0 (0.87)	7.8 (0.31)				
FVF2-4.8	Blue	1.5-2.5	16-14	5.0 (0.20)	20.0 (0.79)	6.4 (0.25)	10.5 (0.41)	2.3 (0.09)	4.5 (0.18)	0.8 (0.03)
FVF2-6.3				6.6 (0.26)	22.0 (0.87)	7.8 (0.31)				
FVF5-6.3	Yellow	4-6	12-10	6.6 (0.26)	24.5 (0.96)	7.8 (0.31)	13.0 (0.51)	3.4 (0.13)	5.5 (0.22)	0.8 (0.03)

VINYL-FULLY INSULATED FEMALE DISCONNECTORS (DOUBLE CRIMP)

- Disconnect can be inserted and removed from the male tab without the use of tools for lower installation cost
- Effectively prevent electric shock hazards caused by current short circuit or accidental touch
- Metal insulation grip sleeve crimps to wire insulation, providing protection to the crimp joint during high vibration applications.
- Internal wire stop assures proper length of insertion into terminal barrel, providing a higher quality connection
- The design of the easy-entry terminal makes the installation process easier
- Provide better conductivity and contact area
- Material: Brass, PVC

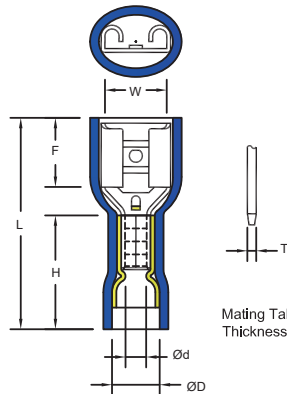

Part No.	Color	Wire Range		Dimension mm (inch)						
		sq. mm.	AWG	W	L	F	H	Ød	ØD	T1
FEVF1-2.8C	Red	0.5-1.5	22-16	3.2 (0.13)	19.4 (0.76)	6.4 (0.25)	10.5 (0.41)	1.7 (0.07)	4.1 (0.16)	0.8 (0.03)
FEVF1-4.8C				5.0 (0.20)	20.0 (0.79)	6.4 (0.25)				
FEVF1-5.2C				5.7 (0.22)	20.0 (0.79)	5.9 (0.23)				
FEVF1-6.3C				6.6 (0.26)	22.0 (0.87)	7.8 (0.31)				
FEVF2-2.8C	Blue	1.5-2.5	16-14	3.2 (0.13)	19.4 (0.76)	6.4 (0.25)	10.5 (0.41)	2.3 (0.09)	4.9 (0.19)	0.8 (0.03)
FEVF2-4.8C				5.0 (0.20)	20.0 (0.79)	6.4 (0.25)				
FEVF2-5.2C				5.7 (0.22)	20.0 (0.79)	5.9 (0.23)				
FEVF5-6.3C	Yellow	4-6	12-10	6.6 (0.26)	24.5 (0.96)	7.8 (0.31)	13.0 (0.51)	3.4 (0.13)	6.7 (0.26)	0.8 (0.03)
FEVF5-9.5C				10.0 (0.39)	29.5 (1.16)	12.0 (0.47)			6.6 (0.26)	0.5 (0.02)

NYLON-FULLY INSULATED FEMALE DISCONNECTORS (EASY-ENTRY)

- Disconnect can be inserted and removed from the male tab without the use of tools for lower installation cost
- Better mechanical strength, high temperature resistance, chemical corrosion resistance and durability
- Effectively prevent electric shock hazards caused by current short circuit or accidental touch
- Metal insulation grip sleeve crimps to wire insulation, providing protection to the crimp joint during high vibration applications.
- Internal wire stop assures proper length of insertion into terminal barrel, providing a higher quality connection
- The design of the easy-entry terminal makes the installation process easier
- Material: Brass, Nylon

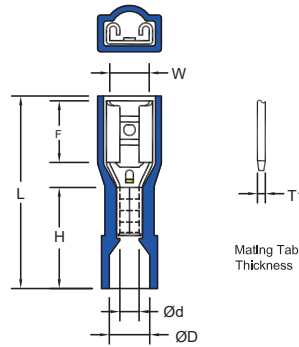

Part No.	Color	Wire Range		Dimension mm (inch)						
		sq. mm.	AWG	W	L	F	H	Ød	ØD	T1
FENF1-4.8	Red	0.5-1.5	22-16	5.0 (0.20)	20.2 (0.80)	6.4 (0.25)	11.0 (0.43)	1.7 (0.07)	4.2 (0.17)	0.8 (0.03)
FENF2-4.8	Blue	1.5-2.5	16-14	5.0 (0.20)	20.2 (0.80)	6.4 (0.25)	11.0 (0.43)	2.3 (0.09)	5.0 (0.20)	0.8 (0.03)

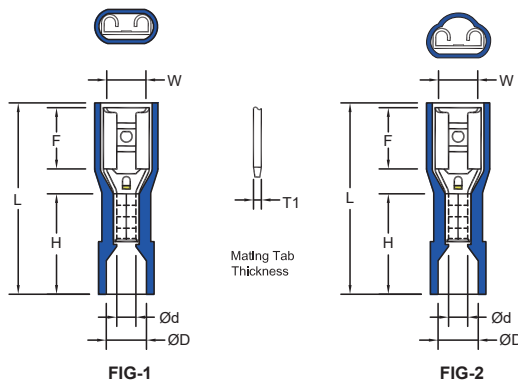

Part No.	Color	Wire Range		Dimension mm (inch)							FIG
		sq. mm.	AWG	W	L	F	H	Ød	ØD	T1	
FENF1-6.3	Red	0.5-1.5	22-16	6.6 (0.26)	22.5 (0.89)	7.8 (0.31)	11.0 (0.43)	1.7 (0.07)	4.2 (0.17)	0.8 (0.03)	1
FENF2-6.3	Blue	1.5-2.5	16-14	6.6 (0.26)	22.5 (0.89)	7.8 (0.31)	11.0 (0.43)	2.3 (0.09)	5.0 (0.20)	0.8 (0.03)	1
FENF5-6.3	Yellow	4-6	12-10	6.6 (0.26)	24.5 (0.96)	7.8 (0.31)	13.0 (0.51)	3.4 (0.13)	6.6 (0.26)	0.8 (0.03)	2

NYLON-FULLY INSULATED FEMALE DISCONNECTORS (DOUBLE CRIMP)

- Disconnect can be inserted and removed from the male tab without the use of tools for lower installation cost
- Better mechanical strength, high temperature resistance, chemical corrosion resistance and durability
- Effectively prevent electric shock hazards caused by current short circuit or accidental touch
- Metal insulation grip sleeve crimps to wire insulation, providing protection to the crimp joint during high vibration applications.
- Internal wire stop assures proper length of insertion into terminal barrel, providing a higher quality connection
- The design of the easy-entry terminal makes the installation process easier
- Provide better conductivity and contact area
- Material: Brass, Nylon

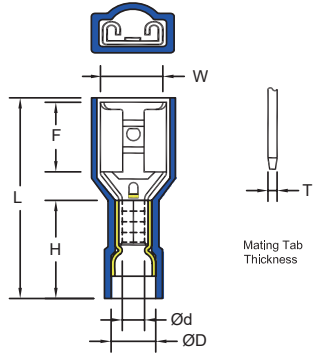

Part No.	Color	Wire Range		Dimension mm (inch)						
		sq. mm.	AWG	W	L	F	H	Ød	ØD	T1
FENF1-4.8C	Red	0.5-1.5	22-16	5.0 (0.20)	20.2 (0.8)	6.4 (0.25)	11.0 (0.43)	1.7 (0.07)	4.2 (0.17)	0.8 (0.03)
FENF2-4.8C	Blue	1.5-2.5	16-14	5.0 (0.20)	20.2 (0.8)	6.4 (0.25)	11.0 (0.43)	2.3 (0.09)	5.0 (0.20)	0.8 (0.03)

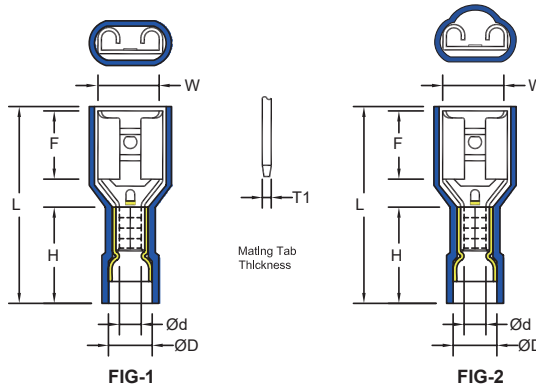

Part No.	Color	Wire Range		Dimension mm (inch)							FIG
		sq. mm.	AWG	W	L	F	H	Ød	ØD	T1	
FENF1-6.3C	Red	0.5-1.5	22-16	6.6 (0.26)	22.5 (0.89)	7.8 (0.31)	11.0 (0.43)	1.7 (0.07)	4.2 (0.17)	0.8 (0.03)	1
FENF2-6.3C	Blue	1.5-2.5	16-14	6.6 (0.26)	22.5 (0.89)	7.8 (0.31)	11.0 (0.43)	2.3 (0.09)	5.0 (0.20)	0.8 (0.03)	1
FENF5-6.3C	Yellow	4-6	12-10	6.6 (0.26)	24.5 (0.96)	7.8 (0.31)	13.0 (0.51)	3.4 (0.13)	6.6 (0.26)	0.8 (0.03)	2

NYLON-FULLY INSULATED MALE DISCONNECTORS (EASY-ENTRY)

- Male tab can be inserted and removed from the female disconnect without the use of tools for lower installation cost
- Better mechanical strength, high temperature resistance, chemical corrosion resistance and durability
- Effectively prevent electric shock hazards caused by current short circuit or accidental touch
- Metal insulation grip sleeve crimps to wire insulation, providing protection to the crimp joint during high vibration applications.
- The design of the easy-entry terminal makes the installation process easier
- Material: Brass, Nylon

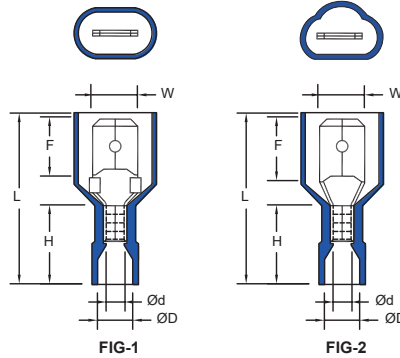

Part No.	Color	Wire Range		Dimension mm (inch)						FIG
		sq. mm.	AWG	W	L	F	H	Ød	ØD	
FENM1-6.3	Red	0.5-1.5	22-16	6.3 (0.25)	24.0 (0.94)	7.8 (0.31)	11.0 (0.43)	1.7 (0.07)	4.2 (0.17)	1
FENM2-6.3	Blue	1.5-2.5	16-14	6.3 (0.25)	24.0 (0.94)	7.8 (0.31)	11.0 (0.43)	2.3 (0.09)	5.0 (0.20)	1
FENM5-6.3	Yellow	4-6	12-10	6.3 (0.25)	25.0 (0.98)	7.8 (0.31)	13.0 (0.51)	3.4 (0.13)	6.6 (0.26)	2

NYLON-FULLY INSULATED MALE DISCONNECTORS (EASY-ENTRY)

- Male tab can be inserted and removed from the female disconnect without the use of tools for lower installation cost
- Better mechanical strength, high temperature resistance, chemical corrosion resistance and durability
- Effectively prevent electric shock hazards caused by current short circuit or accidental touch
- Metal insulation grip sleeve crimps to wire insulation, providing protection to the crimp joint during high vibration applications.
- The design of the easy-entry terminal makes the installation process easier
- Material: Brass, Nylon

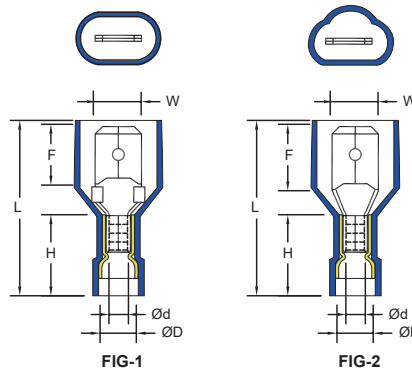

Part No.	Color	Wire Range		Dimension mm (inch)						FIG
		sq. mm.	AWG	W	L	F	H	Ød	ØD	
FENM1-6.3C	Red	0.5-1.5	22-16	6.3 (0.25)	24.0 (0.94)	7.8 (0.31)	11.0 (0.43)	1.7 (0.07)	4.2 (0.17)	1
FENM2-6.3C	Blue	1.5-2.5	16-14	6.3 (0.25)	24.0 (0.94)	7.8 (0.31)	11.0 (0.43)	2.3 (0.09)	5.0 (0.20)	1
FENM5-6.3C	Yellow	4-6	12-10	6.3 (0.25)	25.0 (0.98)	7.8 (0.31)	13.0 (0.51)	3.4 (0.13)	6.6 (0.26)	2

NYLON-FULLY (SQUARE) INSULATED FEMALE DISCONNECTORS (EASY-ENTRY)

- Disconnect can be inserted and removed from the male tab without the use of tools for lower installation cost
- Better mechanical strength, high temperature resistance, chemical corrosion resistance and durability
- Effectively prevent electric shock hazards caused by current short circuit or accidental touch
- Metal insulation grip sleeve crimps to wire insulation, providing protection to the crimp joint during high vibration applications.
- Internal wire stop assures proper length of insertion into terminal barrel, providing a higher quality connection
- The design of the easy-entry terminal makes the installation process easier
- Material: Brass, Nylon

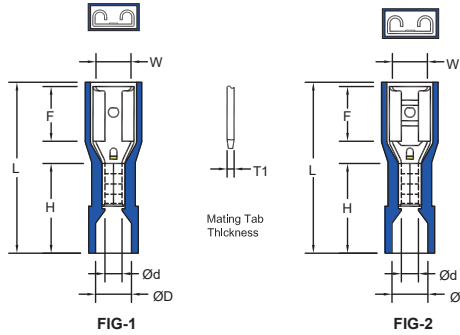

Part No.	Color	Wire Range		Dimension mm (inch)							FIG
		sq. mm.	AWG	W	L	F	H	Ød	ØD	T1	
FENSF1-2.8	Red	0.5-1.5	22-16	3.2 (0.13)	19.5 (0.77)	6.4 (0.25)	11.0 (0.43)	1.7 (0.07)	4.2 (0.17)	0.8 (0.03)	1
FENSF1-6.3	Red	1.5-2.5	16-14	6.6 (0.26)	22.0 (0.87)	7.8 (0.31)	11.0 (0.43)	1.7 (0.07)	4.2 (0.17)	0.8 (0.03)	1
FENSF2-6.3	Blue	4-6	12-10	6.6 (0.26)	22.0 (0.87)	7.8 (0.31)	11.0 (0.43)	2.3 (0.09)	5.0 (0.20)	0.8 (0.03)	2

NYLON-FULLY (SQUARE) INSULATED FEMALE DISCONNECTORS (DOUBLE CRIMP)

- Disconnect can be inserted and removed from the male tab without the use of tools for lower installation cost
- Better mechanical strength, high temperature resistance, chemical corrosion resistance and durability
- Effectively prevent electric shock hazards caused by current short circuit or accidental touch
- Metal insulation grip sleeve crimps to wire insulation, providing protection to the crimp joint during high vibration applications.
- Internal wire stop assures proper length of insertion into terminal barrel, providing a higher quality connection
- The design of the easy-entry terminal makes the installation process easier
- Provide better conductivity and contact area
- Material: Brass, Nylon

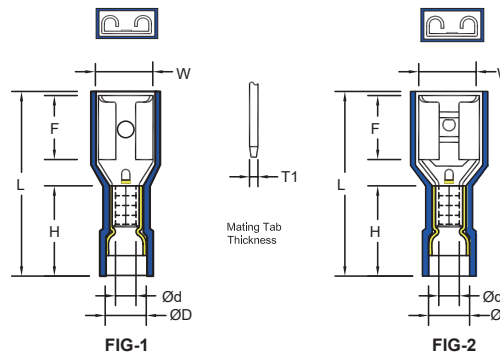

Part No.	Color	Wire Range		Dimension mm (inch)							FIG
		sq. mm.	AWG	W	L	F	H	Ød	ØD	T1	
FENSF1-2.8C	Red	0.5-1.5	22-16	3.2 (0.13)	19.5 (0.77)	6.4 (0.25)	11.0 (0.43)	1.7 (0.07)	4.2 (0.17)	0.8 (0.03)	1
FENSF1-6.3C	Red	1.5-2.5	16-14	6.6 (0.26)	22.0 (0.87)	7.8 (0.31)	11.0 (0.43)	1.7 (0.07)	4.2 (0.17)	0.8 (0.03)	1
FENSF2-6.3C	Blue	4-6	12-10	6.6 (0.26)	22.0 (0.87)	7.8 (0.31)	11.0 (0.43)	2.3 (0.09)	5.0 (0.20)	0.8 (0.03)	2

NYLON-FULLY INSULATED FEMALE DISCONNECTORS (EASY-ENTRY)

- Male tab can be inserted and removed from the female disconnect without the use of tools for lower installation cost
- Better mechanical strength, high temperature resistance, chemical corrosion resistance and durability
- Effectively prevent electric shock hazards caused by current short circuit or accidental touch
- Metal insulation grip sleeve crimps to wire insulation, providing protection to the crimp joint during high vibration applications.
- The design of the easy-entry terminal makes the installation process easier
- Material: Brass, Nylon

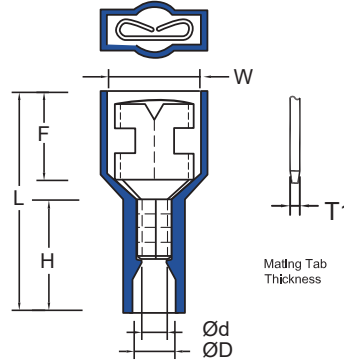

Part No.	Color	Wire Range		Dimension mm (inch)						
		sq. mm.	AWG	W	L	F	H	Ød	ØD	T1
FENF1-6.3A	Red	0.5-1.5	22-16	6.6 (0.26)	22.5 (0.89)	7.8 (0.31)	12.0 (0.47)	1.7 (0.07)	4.0 (0.16)	0.8 (0.03)
FENF2-6.3A	Blue	1.5-2.5	16-14	6.6 (0.26)	22.5 (0.89)	7.8 (0.31)	12.0 (0.47)	2.3 (0.09)	4.5 (0.18)	0.8 (0.03)
FENF5-6.3A	Yellow	4-6	12-10	6.6 (0.26)	23.5 (0.93)	7.8 (0.31)	12.0 (0.47)	3.4 (0.13)	5.0 (0.20)	0.8 (0.03)

NYLON-FULLY INSULATED MALE DISCONNECTORS (EASY-ENTRY)

- Male tab can be inserted and removed from the female disconnect without the use of tools for lower installation cost
- Better mechanical strength, high temperature resistance, chemical corrosion resistance and durability
- Effectively prevent electric shock hazards caused by current short circuit or accidental touch
- Metal insulation grip sleeve crimps to wire insulation, providing protection to the crimp joint during high vibration applications.
- The design of the easy-entry terminal makes the installation process easier
- Material: Brass, Nylon

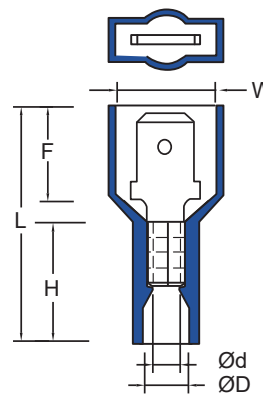

Part No.	Color	Wire Range		Dimension mm (inch)						
		sq. mm.	AWG	W	L	F	H	Ød	ØD	
FENM1-6.3A	Red	0.5-1.5	22-16	6.3 (0.25)	24.5 (0.96)	7.8 (0.31)	11.0 (0.43)	1.7 (0.07)	4.0 (0.16)	
FENM2-6.3A	Blue	1.5-2.5	16-14	6.3 (0.25)	24.5 (0.96)	7.8 (0.31)	11.0 (0.43)	2.3 (0.09)	4.5 (0.18)	
FENM5-6.3A	Yellow	4-6	12-10	6.3 (0.25)	26.0 (1.02)	7.8 (0.31)	13.0 (0.51)	3.4 (0.13)	5.0 (0.20)	

VINYL-INSULATED PIGGYBACK DISCONNECTORS

- Combination of female disconnect and male tab allows versatility in points of connection
- Multiple connection points allow additional circuits to be added to existing equipment without expensive rework
- Metal insulation grip sleeve crimps to wire insulation, providing protection to the crimp joint during high vibration applications
- Material: Brass, PVC

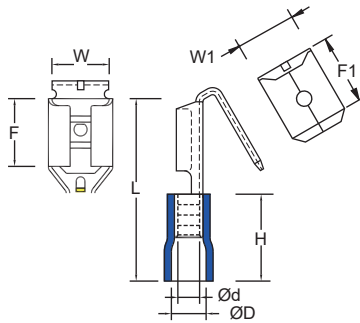

Part No.	Color	Wire Range		Dimension mm (inch)							
		sq. mm.	AWG	W	L	F	H	Ød	ØD	W1	F1
VPB1-6.4	Red	0.5-1.5	22-16	6.6 (0.26)	21.0 (0.83)	7.8 (0.31)	10.0 (0.39)	1.7 (0.07)	4.0 (0.16)	6.3 (0.25)	8.0 (0.31)
VPB2-6.4	Blue	1.5-2.5	16-14	6.6 (0.26)	21.0 (0.83)	7.8 (0.31)	10.0 (0.39)	2.3 (0.09)	4.5 (0.18)	6.3 (0.25)	8.0 (0.31)
VPB5-6.4	Yellow	4-6	12-10	6.6 (0.26)	24.0 (0.94)	7.8 (0.31)	13.0 (0.51)	3.4 (0.13)	5.5 (0.22)	6.3 (0.25)	8.0 (0.31)

VINYL- INSULATED PIGGYBACK DISCONNECTORS (DOUBLE CRIMP)

- Combination of female disconnect and male tab allows versatility in points of connection
- Metal insulation grip sleeve crimps to wire insulation, providing protection to the crimp joint during high vibration applications.
- The design of the easy-entry terminal makes the installation process easier
- Provide better conductivity and contact area
- Material: Brass, PVC

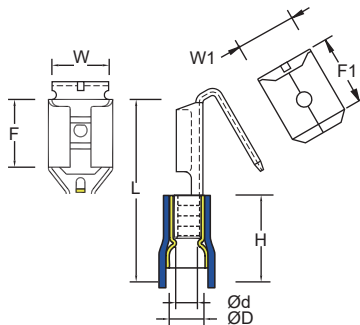

Part No.	Color	Wire Range		Dimension mm (inch)							
		sq. mm.	AWG	W	L	F	H	Ød	ØD	W1	F1
VPB1-6.3C	Red	0.5-1.5	22-16	6.6 (0.26)	21.5 (0.85)	7.8 (0.31)	10.5 (0.41)	1.7 (0.07)	4.0 (0.16)	6.3 (0.25)	8.0 (0.31)
VPB2-6.3C	Blue	1.5-2.5	16-14	6.6 (0.26)	21.5 (0.85)	7.8 (0.31)	10.5 (0.41)	2.3 (0.09)	4.9 (0.19)	6.3 (0.25)	8.0 (0.31)
VPB5-6.3C	Yellow	4-6	12-10	6.6 (0.26)	24 (0.94)	7.8 (0.31)	13 (0.51)	3.4 (0.13)	6.6 (0.26)	6.3 (0.25)	8.0 (0.31)

NYLON- INSULATED PIGGYBACK DISCONNECTORS (EASY-ENTRY)

- Combination of female disconnect and male tab allows versatility in points of connection
- Better mechanical strength, high temperature resistance, chemical corrosion resistance and durability
- Metal insulation grip sleeve crimps to wire insulation, providing protection to the crimp joint during high vibration applications.
- The design of the easy-entry terminal makes the installation process easier
- Material: Brass, Nylon

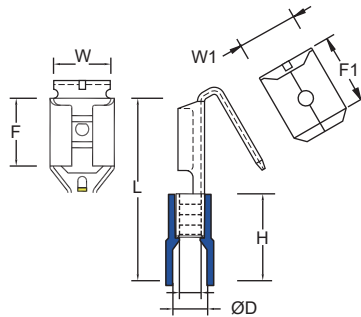

Part No.	Color	Wire Range		Dimension mm (inch)							
		sq. mm.	AWG	W	L	F	H	Ød	ØD	W1	F1
ENPB1-6.3	Red	0.5-1.5	22-16	6.6 (0.26)	22.0 (0.87)	7.8 (0.31)	11.0 (0.43)	1.7 (0.07)	4.1 (0.16)	6.3 (0.25)	8.0 (0.31)
ENPB2-6.3	Blue	1.5-2.5	16-14	6.6 (0.26)	22.0 (0.87)	7.8 (0.31)	11.0 (0.43)	2.3 (0.09)	4.5 (0.18)	6.3 (0.25)	8.0 (0.31)
ENPB5-6.3	Yellow	4-6	12-10	6.6 (0.26)	24.0 (0.94)	7.8 (0.31)	13.0 (0.51)	3.4 (0.13)	6.5 (0.26)	6.3 (0.25)	8.0 (0.31)

NYLON- FULLY INSULATED PIGGYBACK DISCONNECTORS (DOUBLE CRIMP)

- Combination of female disconnect and male tab allows versatility in points of connection
- Metal insulation grip sleeve crimps to wire insulation, providing protection to the crimp joint during high vibration applications.
- Effectively prevent electric shock hazards caused by current short circuit or accidental touch
- The design of the easy-entry terminal makes the installation process easier
- Provide better conductivity and contact area
- Material: Brass, Nylon

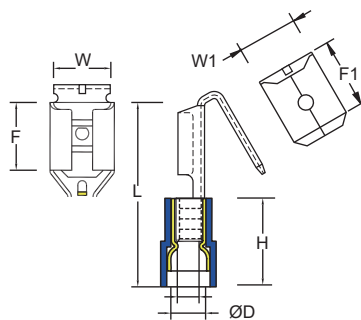

Part No.	Color	Wire Range		Dimension mm (inch)							
		sq. mm.	AWG	W	L	F	H	Ød	ØD	W1	F1
ENPB1-6.3C	Red	0.5-1.5	22-16	6.6 (0.26)	22.0 (0.87)	7.8 (0.31)	11.0 (0.43)	1.7 (0.07)	4.1 (0.16)	6.3 (0.25)	8.0 (0.31)
ENPB2-6.3C	Blue	1.5-2.5	16-14	6.6 (0.26)	22.0 (0.87)	7.8 (0.31)	11.0 (0.43)	2.3 (0.09)	4.9 (0.19)	6.3 (0.25)	8.0 (0.31)
ENPB5-6.3C	Yellow	4-6	12-10	6.6 (0.26)	24.0 (0.94)	7.8 (0.31)	13.0 (0.51)	3.4 (0.13)	6.7 (0.26)	6.3 (0.25)	8.0 (0.31)

VINYL- FULLY INSULATED PIGGYBACK DISCONNECTORS

- Combination of female disconnect and male tab allows versatility in points of connection
- Metal insulation grip sleeve crimps to wire insulation, providing protection to the crimp joint during high vibration applications.
- Effectively prevent electric shock hazards caused by current short circuit or accidental touch
- Material: Brass, PVC

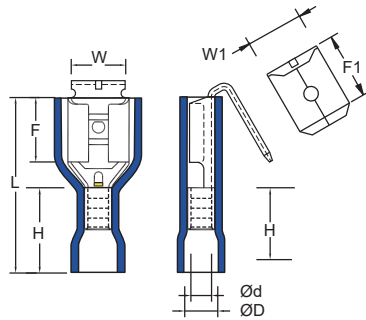

Part No.	Color	Wire Range		W	L	F	H	Ød	ØD	W1	F1
		sq. mm.	AWG								
FVPB1-6.3	Red	0.5-1.5	22-16	6.6 (0.26)	22.0 (0.87)	7.8 (0.31)	10.5 (0.41)	1.7 (0.07)	4.0 (0.16)	6.3 (0.25)	8.0 (0.31)
FVPB2-6.3	Blue	1.5-2.5	16-14	6.6 (0.26)	22.0 (0.87)	7.8 (0.31)	10.5 (0.41)	2.3 (0.09)	4.5 (0.18)	6.3 (0.25)	8.0 (0.31)
FVPB5-6.3	Yellow	4-6	12-10	6.6 (0.26)	24.5 (0.96)	7.8 (0.31)	13.0 (0.51)	3.4 (0.13)	5.5 (0.22)	6.3 (0.25)	8.0 (0.31)

VINYL- FULLY INSULATED PIGGYBACK DISCONNECTORS (DOUBLE CRIMP)

- Combination of female disconnect and male tab allows versatility in points of connection
- Metal insulation grip sleeve crimps to wire insulation, providing protection to the crimp joint during high vibration applications.
- Effectively prevent electric shock hazards caused by current short circuit or accidental touch
- The design of the easy-entry terminal makes the installation process easier
- Provide better conductivity and contact area
- Material: Brass, PVC

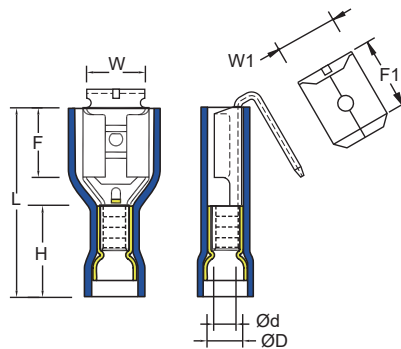

Part No.	Color	Wire Range		W	L	F	H	Ød	ØD	W1	F1
		sq. mm.	AWG								
FEVPB1-6.3C	Red	0.5-1.5	22-16	6.6 (0.26)	22.0 (0.87)	7.8 (0.31)	10.5 (0.41)	1.7 (0.07)	4.1 (0.16)	6.3 (0.25)	8.0 (0.31)
FEVPB2-6.3C	Blue	1.5-2.5	16-14	6.6 (0.26)	22.0 (0.87)	7.8 (0.31)	10.5 (0.41)	2.3 (0.09)	4.9 (0.19)	6.3 (0.25)	8.0 (0.31)
FEVPB5-6.3C	Yellow	4-6	12-10	6.6 (0.26)	24.5 (0.96)	7.8 (0.31)	13.0 (0.51)	3.4 (0.13)	6.7 (0.26)	6.3 (0.25)	8.0 (0.31)

NYLON- FULLY INSULATED PIGGYBACK DISCONNECTORS (EASY-ENTRY)

- Combination of female disconnect and male tab allows versatility in points of connection
- Metal insulation grip sleeve crimps to wire insulation, providing protection to the crimp joint during high vibration applications.
- Effectively prevent electric shock hazards caused by current short circuit or accidental touch
- The design of the easy-entry terminal makes the installation process easier
- Material: Brass, Nylon

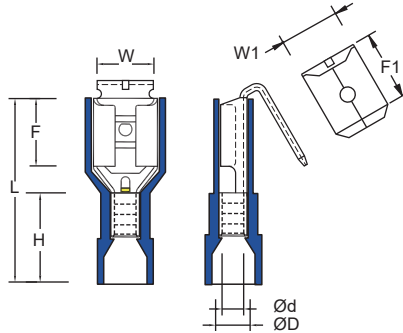

Part No.	Color	Wire Range		W	L	F	H	Ød	ØD	W1	F1
		sq. mm.	AWG								
FENPB1-6.3	Red	0.5-1.5	22-16	6.6 (0.26)	22.5 (0.89)	7.8 (0.31)	11.0 (0.43)	1.7 (0.07)	4.2 (0.17)	6.3 (0.25)	8.0 (0.31)
FENPB2-6.3	Blue	1.5-2.5	16-14	6.6 (0.26)	22.5 (0.89)	7.8 (0.31)	11.0 (0.43)	2.3 (0.09)	5.0 (0.20)	6.3 (0.25)	8.0 (0.31)
FENPB5-6.3	Yellow	4-6	12-10	6.6 (0.26)	24.5 (0.96)	7.8 (0.31)	13.0 (0.51)	3.4 (0.13)	6.6 (0.26)	6.3 (0.25)	8.0 (0.31)

NYLON- FULLY INSULATED PIGGYBACK DISCONNECTORS (DOUBLE CRIMP)

- Combination of female disconnect and male tab allows versatility in points of connection
- Metal insulation grip sleeve crimps to wire insulation, providing protection to the crimp joint during high vibration applications.
- Effectively prevent electric shock hazards caused by current short circuit or accidental touch
- The design of the easy-entry terminal makes the installation process easier
- Provide better conductivity and contact area
- Material: Brass, Nylon

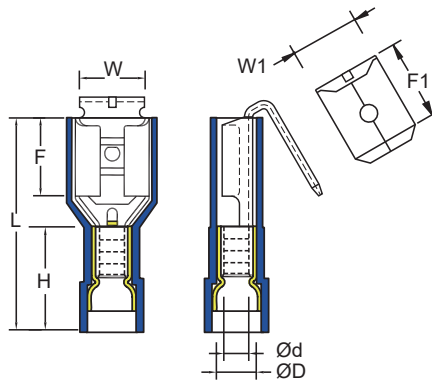

Part No.	Color	Wire Range		W	L	F	H	Ød	ØD	W1	F1
		sq. mm.	AWG								
FENPB1-6.3C	Red	0.5-1.5	22-16	6.6 (0.26)	22.5 (0.89)	7.8 (0.31)	11.0 (0.43)	1.7 (0.07)	4.2 (0.17)	6.3 (0.25)	8.0 (0.31)
FENPB2-6.3C	Blue	1.5-2.5	16-14	6.6 (0.26)	22.5 (0.89)	7.8 (0.31)	11.0 (0.43)	2.3 (0.09)	5.0 (0.20)	6.3 (0.25)	8.0 (0.31)
FENPB5-6.3C	Yellow	4-6	12-10	6.6 (0.26)	24.5 (0.96)	7.8 (0.31)	13.0 (0.51)	3.4 (0.13)	6.6 (0.26)	6.3 (0.25)	8.0 (0.31)

VINYL-INSULATED BULLET DISCONNECTORS

- Male bullet connector couples with female one
- Male bullet connector can be inserted and removed from the female disconnect without the use of tools for lower installation cost
- Metal insulation grip sleeve crimps to wire insulation, providing protection to the crimp joint during high vibration applications
- Material: Brass, PVC

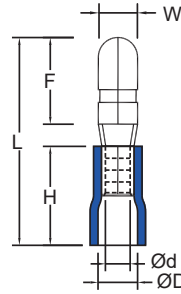

Part No.	Color	Wire Range		Dimension mm (inch)					
		sq. mm.	AWG	ØW	L	F	H	Ød	ØD
VBM1-4	Red	0.5-1.5	22-16	4.0 (0.16)	21.0 (0.83)	8.7 (0.34)	10.0 (0.39)	1.7 (0.07)	4.0 (0.16)
VBM2-4	Blue	1.5-2.5	16-14	4.0 (0.16)	21.0 (0.83)	8.7 (0.34)	10.0 (0.39)	2.3 (0.09)	4.5 (0.18)
VBM2-5				5.0 (0.20)	21.0 (0.83)	8.9 (0.35)			
VBM5-5	Yellow	4-6	12-10	5.0 (0.20)	24.0 (0.94)	8.9 (0.35)	13.0 (0.51)	3.4 (0.13)	5.5 (0.22)

VINYL-INSULATED BULLET DISCONNECTORS (DOUBLE CRIMP)

- Male bullet connector can be inserted and removed from the female disconnect without the use of tools of lower installation cost
- Metal insulation grip sleeve crimps to wire insulation, providing protection to the crimp joint during high vibration applications.
- The design of the easy-entry terminal makes the installation process easier
- Provide better conductivity and contact area
- Material: Brass, PVC

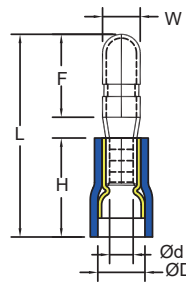

Part No.	Color	Wire Range		Dimension mm (inch)					
		sq. mm.	AWG	ØW	L	F	H	Ød	ØD
EVBM1-4C	Red	0.5-1.5	22-16	4.0 (0.16)	21.5 (0.85)	8.7 (0.34)	10.5 (0.41)	1.7 (0.07)	4.0 (0.16)
EVBM2-4C	Blue	1.5-2.5	16-14	4.0 (0.16)	21.5 (0.85)	8.7 (0.34)	10.5 (0.41)	2.3 (0.09)	4.9 (0.19)
EVBM2-5C				5.0 (0.20)	21.5 (0.85)	8.9 (0.35)			
EVBM5-5C	Yellow	4-6	12-10	5.0 (0.20)	24.0 (0.94)	8.9 (0.35)	13.0 (0.51)	3.4 (0.13)	6.7 (0.26)

NYLON-INSULATED BULLET DISCONNECTORS (EASY-ENTRY)

- Male bullet connector can be inserted and removed from the female disconnect without the use of tools of lower installation cost
- Better mechanical strength, high temperature resistance, chemical corrosion resistance and durability
- Metal insulation grip sleeve crimps to wire insulation, providing protection to the crimp joint during high vibration applications.
- The design of the easy-entry terminal makes the installation process easier
- Material: Brass, Nylon

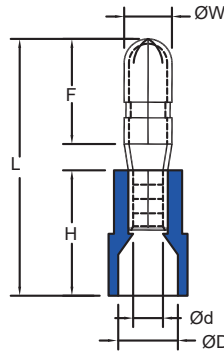

Part No.	Color	Wire Range		Dimension mm (inch)					
		sq. mm.	AWG	ØW	L	F	H	Ød	ØD
ENBM1-4	Red	0.5-1.5	22-16	4.0 (0.16)	22.0 (0.87)	8.7 (0.34)	11.0 (0.43)	1.7 (0.07)	4.1 (0.16)
ENBM2-4	Blue	1.5-2.5	16-14	4.0 (0.16)	22.0 (0.87)	8.7 (0.34)	11.0 (0.43)	2.3 (0.09)	4.5 (0.18)
ENBM2-5				5.0 (0.20)	22.0 (0.87)	8.9 (0.35)			
ENBM5-5	Yellow	4-6	12-10	5.0 (0.20)	24.0 (0.94)	8.9 (0.35)	13.0 (0.51)	3.4 (0.13)	6.5 (0.26)

NYLON-INSULATED BULLET DISCONNECTORS (DOUBLE CRIMP)

- Male bullet connector can be inserted and removed from the female disconnect without the use of tools of lower installation cost
- Better mechanical strength, high temperature resistance, chemical corrosion resistance and durability
- Metal insulation grip sleeve crimps to wire insulation, providing protection to the crimp joint during high vibration applications.
- The design of the easy-entry terminal makes the installation process easier
- Provide better conductivity and contact area
- Material: Brass, Nylon

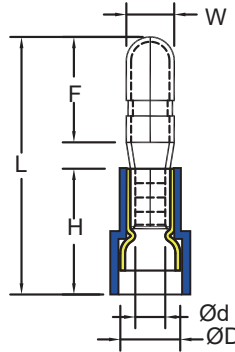

Part No.	Color	Wire Range		Dimension mm (inch)					
		sq. mm.	AWG	ØW	L	F	H	Ød	ØD
ENBM1-4C	Red	0.5-1.5	22-16	4.0 (0.16)	22.0 (0.87)	8.7 (0.34)	11.0 (0.43)	1.7 (0.07)	4.1 (0.16)
ENBM2-4C	Blue	1.5-2.5	16-14	4.0 (0.16)	22.0 (0.87)	8.7 (0.34)	11.0 (0.43)	2.3 (0.09)	4.9 (0.19)
ENBM2-5C				5.0 (0.20)	22.0 (0.87)	8.9 (0.35)			
ENBM5-5C	Yellow	4-6	12-10	5.0 (0.20)	24.0 (0.94)	8.9 (0.35)	13.0 (0.51)	3.4 (0.13)	6.7 (0.26)

NYLON-FULLY INSULATED BULLET DISCONNECTORS (EASY-ENTRY)

- Male bullet connector can be inserted and removed from the female disconnect without the use of tools of lower installation cost
- Effectively prevent electric shock hazards caused by current short circuit or accidental touch
- Metal insulation grip sleeve crimps to wire insulation, providing protection to the crimp joint during high vibration applications.
- The design of the easy-entry terminal makes the installation process easier
- Material: Brass, Nylon

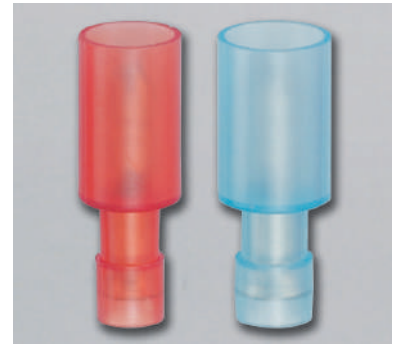
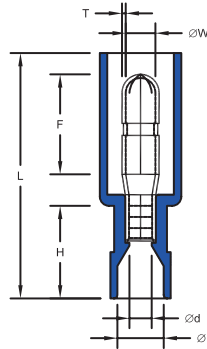

Part No.	Color	Wire Range		Dimension mm (inch)					
		sq. mm.	AWG	ØW	L	F	H	Ød	ØD
FENBM1-4	Red	0.5-1.5	22-16	3.9 (0.15)	26.5 (1.04)	10.7 (0.42)	10.0 (0.39)	1.7 (0.07)	4.2 (0.17)
FENBM2-4	Blue	1.5-2.5	16-14	3.9 (0.15)	26.5 (1.04)	10.7 (0.42)	10.0 (0.39)	2.3 (0.09)	5.0 (0.20)

NYLON-FULLY INSULATED BULLET DISCONNECTORS (DOUBLE CRIMP)

- Male bullet connector can be inserted and removed from the female disconnect without the use of tools of lower installation cost
- Effectively prevent electric shock hazards caused by current short circuit or accidental touch
- Metal insulation grip sleeve crimps to wire insulation, providing protection to the crimp joint during high vibration applications.
- The design of the easy-entry terminal makes the installation process easier
- Provide better conductivity and contact area
- Material: Brass, Nylon

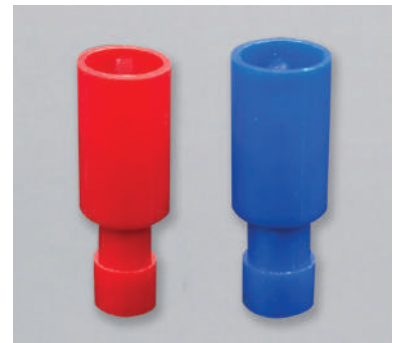
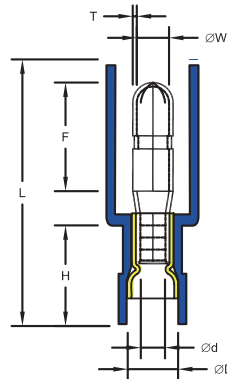

Part No.	Color	Wire Range		Dimension mm (inch)					
		sq. mm.	AWG	ØW	L	F	H	Ød	ØD
FENBM1-4C	Red	0.5-1.5	22-16	3.9 (0.15)	26.5 (1.04)	10.7 (0.42)	10.0 (0.39)	1.7 (0.07)	4.2 (0.17)
FENBM2-4C	Blue	1.5-2.5	16-14	3.9 (0.15)	26.5 (1.04)	10.7 (0.42)	10.0 (0.39)	2.3 (0.09)	5.0 (0.20)

VINYL-FULLY INSULATED RECEPTACLE DISCONNECTORS

- Disconnect can be inserted and removed from the male bullet without the use of tools for lower installation cost
- Metal insulation grip sleeve crimps to wire insulation, providing protection to the crimp joint during high vibration applications
- Internal wire stop assures proper length of insertion into terminal barrel, providing a higher quality connection
- Material: Brass, PVC

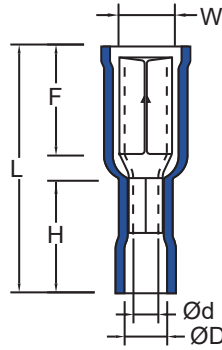

Part No.	Color	Wire Range		Dimension mm (inch)					
		sq. mm.	AWG	ØW	L	F	H	Ød	ØD
FVBF1-4	Red	0.5-1.5	22-16	3.9 (0.15)	22.5 (0.89)	8.7 (0.34)	10.5 (0.41)	1.7 (0.07)	4.0 (0.16)
FVBF2-4	Blue	1.5-2.5	16-14	3.9 (0.15)	22.5 (0.89)	8.7 (0.34)	10.5 (0.41)	2.3 (0.09)	4.5 (0.18)
FVBF2-5				4.9 (0.19)	22.5 (0.89)	8.8 (0.35)			
FVBF5-5	Yellow	4-6	12-10	4.9 (0.19)	25.0 (0.98)	8.8 (0.35)	13.0 (0.51)	3.4 (0.13)	5.5 (0.22)

VINYL-FULLY INSULATED RECEPTACLE DISCONNECTORS (DOUBLE CRIMP)

- Disconnect can be inserted and removed from the male bullet without the use of tools of lower installation cost
- Effectively prevent electric shock hazards caused by current short circuit or accidental touch
- Metal insulation grip sleeve crimps to wire insulation, providing protection to the crimp joint during high vibration applications.
- The design of the easy-entry terminal makes the installation process easier
- Provide better conductivity and contact area
- Material: Brass, PVC

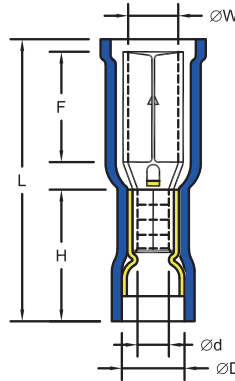

Part No.	Color	Wire Range		Dimension mm (inch)					
		sq. mm.	AWG	ØW	L	F	H	Ød	ØD
FEVBF1-4C	Red	0.5-1.5	22-16	3.9 (0.15)	22.5 (0.89)	8.7 (0.34)	10.5 (0.41)	1.7 (0.07)	4.1 (0.16)
FEVBF2-4C	Blue	1.5-2.5	16-14	3.9 (0.15)	22.5 (0.89)	8.7 (0.34)	10.5 (0.41)	2.3 (0.09)	4.9 (0.19)
FEVBF2-5C				4.9 (0.19)	22.5 (0.89)	8.8 (0.35)			
FEVBF5-5C	Yellow	4-6	12-10	4.9 (0.19)	25.0 (0.98)	8.8 (0.35)	13.0 (0.51)	3.4 (0.13)	6.7 (0.26)

NYLON-FULLY INSULATED RECEPTACLE DISCONNECTORS (EASY-ENTRY)

- Disconnect can be inserted and removed from the male bullet without the use of tools of lower installation cost
- Effectively prevent electric shock hazards caused by current short circuit or accidental touch
- Metal insulation grip sleeve crimps to wire insulation, providing protection to the crimp joint during high vibration applications.
- The design of the easy-entry terminal makes the installation process easier
- Material: Brass, Nylon

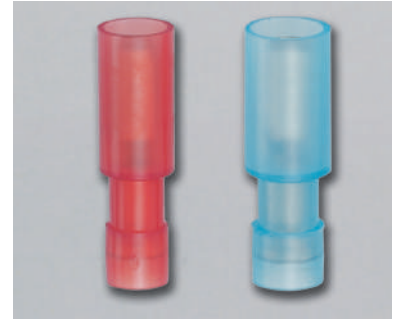
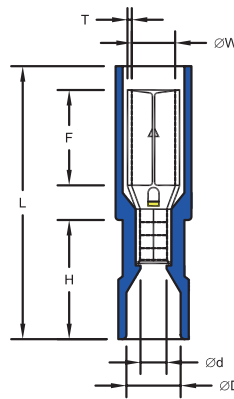

Part No.	Color	Wire Range		Dimension mm (inch)					
		sq. mm.	AWG	ØW	L	F	H	Ød	ØD
FENBF1-4	Red	0.5-1.5	22-16	4.0 (0.16)	25.2 (0.99)	8.7 (0.34)	11.0 (0.43)	1.7 (0.07)	4.0 (0.16)
FENBF2-4	Blue	1.5-2.5	16-14	4.0 (0.16)	25.2 (0.99)	8.7 (0.34)	11.0 (0.43)	2.3 (0.09)	5.0 (0.20)

NYLON-FULLY INSULATED RECEPTACLE DISCONNECTORS (DOUBLE CRIMP)

- Disconnect can be inserted and removed from the male bullet without the use of tools of lower installation cost
- Effectively prevent electric shock hazards caused by current short circuit or accidental touch
- Metal insulation grip sleeve crimps to wire insulation, providing protection to the crimp joint during high vibration applications.
- The design of the easy-entry terminal makes the installation process easier
- Provide better conductivity and contact area
- Material: Brass, Nylon

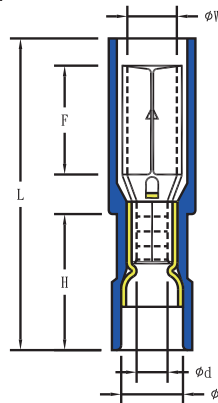

Part No.	Color	Wire Range		Dimension mm (inch)					
		sq. mm.	AWG	ØW	L	F	H	Ød	ØD
FENBF1-4C	Red	0.5-1.5	22-16	4.0 (0.16)	25.2 (0.99)	8.7 (0.34)	11.0 (0.43)	1.7 (0.07)	4.2 (0.17)
FENBF2-4C	Blue	1.5-2.5	16-14	4.0 (0.16)	25.2 (0.99)	8.7 (0.34)	11.0 (0.43)	2.3 (0.09)	5.0 (0.20)

NON-INSULATED BUTT CONNECTORS

- Designed to splice two solid or stranded wires together to repair or lengthen wires
- Brazed seam protects terminal barrel from splitting during the crimping process
- Material: Copper

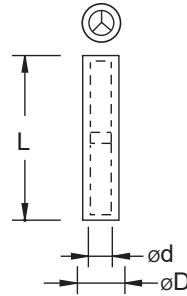

Part No.	Wire Range		Dimension mm (inch)		
	sq. mm.	AWG	Ød	L	ØD
I1	0.5-1.5	22-16	1.8 (0.07)	15.0 (0.59)	3.3 (0.13)
I2	1.5-2.5	16-14	2.4 (0.09)	15.0 (0.59)	4.0 (0.16)
I5	4-6	12-10	3.6 (0.14)	15.0 (0.59)	5.5 (0.22)
I8	8	8	4.6 (0.18)	21.0 (0.83)	7.0 (0.28)
I14	14	6	5.9 (0.23)	26.0 (1.02)	8.9 (0.35)
I22	22	4	7.7 (0.30)	29.0 (1.14)	11.4 (0.45)
I38	38	2	9.4 (0.37)	32.0 (1.26)	13.3 (0.52)
I60	60	1/0	11.4 (0.45)	36.0 (1.42)	15.4 (0.61)
I70	70	2/0	13.3 (0.52)	37.0 (1.46)	17.5 (0.69)
I80	80	3/0	14.5 (0.57)	38.0 (1.50)	19.4 (0.76)
I100	100	4/0	16.4 (0.65)	38.0 (1.50)	22.0 (0.87)
I150	150	250/300	19.5 (0.77)	54.0 (2.13)	26.5 (1.04)
I180	180	300/350	21.0 (0.83)	57.0 (2.24)	28.5 (1.12)
I200	200	400/500	24.0 (0.94)	63.0 (2.48)	32.5 (1.28)
I325	325	500/600	28.0 (1.1)	72.0 (2.83)	37.0 (1.46)

NON-INSULATED PARALLEL CONNECTORS

- Designed to splice two solid or stranded wires together to repair or lengthen wires
- Brazed seam protects terminal barrel from splitting during the crimping process
- Material: Copper

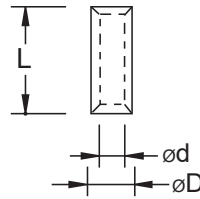

Part No.	Wire Range		Dimension mm (inch)		
	sq. mm.	AWG	ød	L	øD
IS1	0.5-1.5	22-16	1.8 (0.07)	8.0 (0.31)	3.3 (0.13)
IS2	1.5-2.5	16-14	2.4 (0.09)	8.0 (0.31)	4.0 (0.16)
IS5	4-6	12-10	3.6 (0.14)	8.5 (0.33)	5.5 (0.22)
IS8	8	8	4.6 (0.18)	9.5 (0.37)	7.0 (0.28)
IS14	14	6	5.8 (0.23)	11.0 (0.43)	9.0 (0.35)
IS22	22	4	7.7 (0.30)	13.5 (0.53)	11.4 (0.45)
IS38	38	2	9.4 (0.37)	16.5 (0.65)	13.3 (0.52)
IS60	60	1/0	11.4 (0.45)	18.5 (0.73)	15.4 (0.61)
IS70	70	2/0	13.3 (0.52)	19.0 (0.75)	17.5 (0.69)
IS80	80	3/0	14.5 (0.57)	19.5 (0.77)	19.4 (0.76)
IS100	100	4/0	16.4 (0.65)	20.0 (0.79)	22.0 (0.87)
IS150	150	250/300	19.5 (0.77)	27.0 (1.06)	26.5 (1.04)
IS180	180	300/350	21.0 (0.83)	28.5 (1.12)	28.5 (1.12)
IS200	200	400/500	24.0 (0.94)	32.0 (1.26)	32.5 (1.28)
IS325	325	500/600	28.0 (1.10)	37.0 (1.46)	37.0 (1.46)

VINYL-INSULATED BUTT SPLICE CONNECTORS

- Expanded wire entry designed to accommodate wires with a larger insulation thickness
- Designed to splice two solid or stranded wires together to repair or lengthen wires
- Brazed seam protects terminal barrel from splitting during the crimping process
- Internal wire stop assures proper length of insertion into terminal barrel
- Material: Copper tube with tin plated end sleeves with insulation PVC

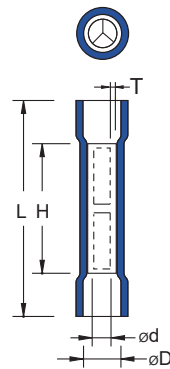

Part No.	Material	Color	Wire Range		Dimension mm (inch)		
			sq. mm.	AWG	L	ød	øD
VI1	Copper Plate	Red	0.5-1.5	22-16	25.0 (0.98)	1.7 (0.07)	4.2 (0.17)
VI1T	Copper Tubular				25.0 (0.98)	1.7 (0.07)	4.2 (0.17)
VI2	Copper Plate	Blue	1.5-2.5	16-14	25.0 (0.98)	2.3 (0.09)	4.9 (0.19)
VI2T	Copper Tubular				25.0 (0.98)	2.3 (0.09)	4.9 (0.19)
VI5	Copper Plate	Yellow	4-6	12-10	25.0 (0.98)	3.4 (0.13)	6.6 (0.26)
VI5T	Copper Tubular				26.0 (1.02)	3.4 (0.13)	6.6 (0.26)

NYLON-INSULATED BUTT SPLICE CONNECTORS (COPPER TUBULAR)

- Designed to splice two solid or stranded wires together to repair or lengthen wires
- Insulation support helps to prevent wire damage in bending applications
- Better mechanical strength, high temperature resistance, chemical corrosion resistance and durability
- Material: Copper tube with tin plated end sleeves with insulation Nylon

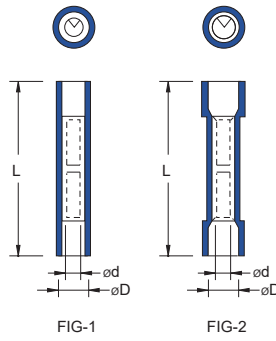

Part No.	Color	Wire Range		Dimension mm (inch)			FIG
		sq. mm.	AWG	L	Ød	ØD	
NI0.5		0.5-1.5	22-16	20.0 (0.79)	1.2 (0.05)	2.0 (0.08)	1
NI1	Red	0.5-1.5	22-16	26.0 (1.02)	1.7 (0.07)	4.1 (0.16)	2
NI2	Blue	1.5-2.5	16-14	26.0 (1.02)	2.3 (0.09)	4.5 (0.18)	2
NI5	Yellow	4-6	12-10	27.0 (1.06)	3.4 (0.13)	6.5 (0.26)	2

HEAT SHRINKABLE-BUTT SPLICE CONNECTORS

- Designed to splice two solid or stranded wires together to repair or lengthen wires
- Insulation support helps to prevent wire damage in bending applications
- Effectively prevent electric shock hazards caused by current short circuit or accidental touch
- Provides excellent electrical insulation, sealing, waterproof, corrosion resistance and temperature resistance
- Material: Copper tube with tin plated end sleeves with insulation high density PE

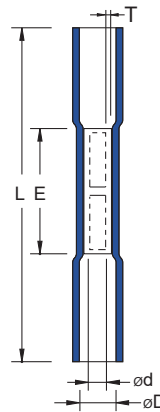

Part No.	Color	Wire Range		Dimension mm (inch)		
		sq. mm.	AWG	Ød	L	E
HI1	Red	0.5-1.5	22-16	1.7 (0.07)	37.0 (1.46)	15.0 (0.59)
HI2	Blue	1.5-2.5	16-14	2.3 (0.09)	37.0 (1.46)	15.0 (0.59)
HI5	Yellow	4-6	12-10	3.4 (0.13)	41.0 (1.61)	15.0 (0.59)

NYLON INSULATED FLAG FEMALE DISCONNECTORS (EASY-ENTRY)

- Disconnect can be inserted and removed from the male tab without the use of tools for lower installation cost
- Better mechanical strength, high temperature resistance, chemical corrosion resistance and durability
- Effectively prevent electric shock hazards caused by current short circuit or accidental touch
- Metal insulation grip sleeve crimps to wire insulation, providing protection to the crimp joint during high vibration applications.
- The design of the easy-entry terminal makes the installation process easier
- Material: Brass, Nylon

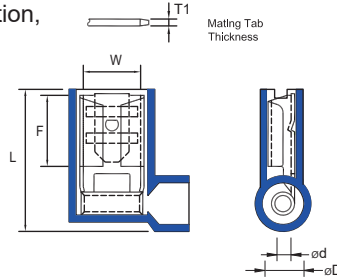

Part No.	Color	Wire Range		Dimension mm (inch)						
		sq. mm.	AWG	ØW	W	L	F	Ød	ØD	T
FENL1-6.3	Red	0.5-1.5	22-16	4.0 (0.16)	6.6 (0.26)	16 (0.63)	7.8 (0.31)	1.7 (0.07)	4.4 (0.17)	0.8 (0.03)
FENL2-6.3	Blue	1.5-2.5	16-14	4.0 (0.16)	6.6 (0.26)	16 (0.63)	7.8 (0.31)	2.3 (0.09)	5.0 (0.20)	0.8 (0.03)

QUICK SPLICES

- Metal connector can cut through the insulation of both wires and make a firm electrical connection between them, all in one action
- The folding cover of the connector can be closed to provide further protection of the connection
- Material: Brass, PP

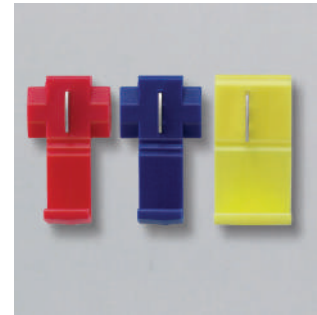

QST Type

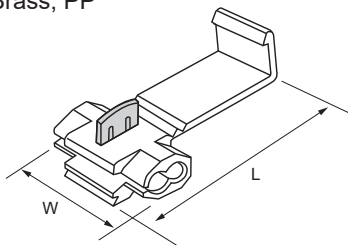

QSA Type

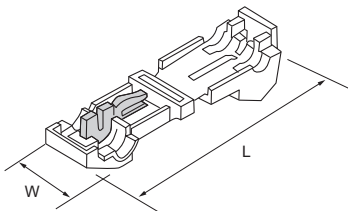

Part No.	Color	Wire Range		Dimension mm (inch)	
		sq. mm.	AWG	W	L
QST1	Red	0.5-1.5	22-18	19.5 (0.77)	30.5 (1.20)
QST2	Blue	1.5-2.5	16-14	19.5 (0.77)	30.5 (1.20)
QST5	Yellow	4-6	12-10	20.0 (0.79)	32.0 (1.26)
QSA1	Red	0.5-1.5	22-18	9.5 (0.37)	38.0 (1.50)
QSA2	Blue	1.5-2.5	16-14	9.5 (0.37)	38.0 (1.50)

COPPER/CABLE LUGS

- Made from superior grade of cooper to ensure most efficient electrical conductivity
- Surface is electrolytically tin-plated to avoid oxidation
- Comply with DIN 46234 for wire containment
- Cooper tube is special designed to reach the most strength to resist vibration and pull out
- The length of lug barrel is designed to allow easy and accurate crimping operation
- Material: Copper

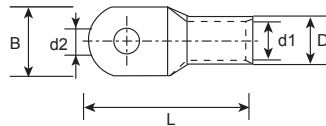

Part No.	Wire Range		Dimension mm (inch)						
	sq. mm.	AWG	B	Ød2	L	F	E	Ød	ØD
SC10-6	10	8	10.0 (0.39)	6.4 (0.25)	25.0 (0.98)	10.0 (0.39)	9.0 (0.35)	4.5 (0.18)	6.2 (0.24)
SC10-8	10	8	12.6 (0.50)	8.4 (0.33)	26.0 (1.02)	10.0 (0.39)	9.0 (0.35)	4.5 (0.18)	6.2 (0.24)
SC16-8	16	6	12.6 (0.50)	8.4 (0.33)	30.0 (1.18)	11.0 (0.43)	12.0 (0.47)	5.4 (0.21)	7.1 (0.28)
SC25-8	25	4	12.6 (0.50)	8.4 (0.33)	30.0 (1.18)	11.0 (0.43)	12.0 (0.47)	6.8 (0.27)	8.8 (0.35)
SC35-8	35	2	15.0 (0.59)	8.4 (0.33)	35.0 (1.38)	14.0 (0.55)	13.0 (0.51)	8.2 (0.32)	10.6 (0.42)
SC35-10	35	2	15.0 (0.59)	10.5 (0.41)	35.0 (1.38)	14.0 (0.55)	13.0 (0.51)	8.2 (0.32)	10.6 (0.42)
SC50-8	50	1/0	18.0 (0.71)	8.4 (0.33)	43.0 (1.69)	17.0 (0.67)	16.0 (0.63)	9.5 (0.37)	12.4 (0.49)
SC50-10	50	1/0	18.0 (0.71)	10.5 (0.41)	43.0 (1.69)	17.0 (0.67)	16.0 (0.63)	9.5 (0.37)	12.4 (0.49)
SC50-12	50	1/0	19.0 (0.75)	13.0 (0.51)	43.0 (1.69)	17.0 (0.67)	16.0 (0.63)	9.5 (0.37)	12.4 (0.49)
SC70-10	70	2/0	21.0 (0.83)	10.5 (0.41)	50.0 (1.97)	18.0 (0.71)	20.0 (0.79)	11.2 (0.44)	14.7 (0.58)
SC95-10	95	3/0	25.5 (1.00)	10.5 (0.41)	55.0 (2.17)	22.0 (0.87)	20.0 (0.79)	13.5 (0.53)	17.4 (0.69)
SC95-12	95	3/0	25.5 (1.00)	13.0 (0.51)	55.0 (2.17)	22.0 (0.87)	20.0 (0.79)	13.5 (0.53)	17.4 (0.69)
SC120-10	120	4/0	28.0 (1.10)	10.5 (0.41)	60.0 (2.36)	24.0 (0.94)	22.0 (0.87)	15.0 (0.59)	19.4 (0.76)
SC120-12	120	4/0	28.0 (1.10)	13.0 (0.51)	60.0 (2.36)	24.0 (0.94)	22.0 (0.87)	15.0 (0.59)	19.4 (0.76)
SC120-14	120	4/0	28.0 (1.10)	15.0 (0.59)	60.0 (2.36)	24.0 (0.94)	22.0 (0.87)	15.0 (0.59)	19.4 (0.76)
SC150-12	150	250/300	30.5 (1.20)	13.0 (0.51)	69.0 (2.72)	27.0 (1.06)	26.0 (1.02)	16.5 (0.65)	21.2 (0.83)
SC150-14	150	250/300	30.5 (1.20)	15.0 (0.59)	69.0 (2.72)	27.0 (1.06)	26.0 (1.02)	16.5 (0.65)	21.2 (0.83)
SC150-16	150	250/300	30.5 (1.20)	17.0 (0.67)	69.0 (2.72)	27.0 (1.06)	26.0 (1.02)	16.5 (0.65)	21.2 (0.83)
SC185-12	185	300/350	34.0 (1.34)	13.0 (0.51)	78.0 (3.07)	29.0 (1.14)	32.0 (1.26)	18.5 (0.73)	23.5 (0.93)
SC185-14	185	300/350	34.0 (1.34)	15.0 (0.59)	78.0 (3.07)	29.0 (1.14)	32.0 (1.26)	18.5 (0.73)	23.5 (0.93)
SC185-16	185	300/350	34.0 (1.34)	17.0 (0.67)	78.0 (3.07)	29.0 (1.14)	32.0 (1.26)	18.5 (0.73)	23.5 (0.93)
SC240-14	240	400/450	38.5 (1.52)	15.0 (0.59)	92.0 (3.62)	34.0 (1.34)	38.0 (1.5)	21.0 (0.83)	26.5 (1.04)
SC240-16	240	400/450	38.5 (1.52)	17.0 (0.67)	92.0 (3.62)	34.0 (1.34)	38.0 (1.5)	21.0 (0.83)	26.5 (1.04)
SC300-14	300	500	43.5 (1.71)	15.0 (0.59)	101.0 (3.98)	37.0 (1.46)	42.0 (1.65)	23.5 (0.93)	30.0 (1.18)
SC300-16	300	500	43.5 (1.71)	17.0 (0.67)	101.0 (3.98)	37.0 (1.46)	42.0 (1.65)	23.5 (0.93)	30.0 (1.18)

CHOICE AND CRIMPING OF TERMINALS

Choice of The Connector

In order to obtain a connection that can be guaranteed for a long time it is necessary to select the connector suitable to the application field and strictly conformed to the section of the cable to be crimped (see the table below). In the large range of Hua Wei's products you will certainly find the ideal solution for every requirement.

Conductor			Conductor			Conductor		
AWG	Area (sq.mm)	Diameter (mm)	AWG	Area (sq.mm)	Diameter (mm)	MCM	Area (sq.mm)	Diameter (mm)
22	0.324	0.643	9	6.63	2.91	250	126.6	12.7
21	0.412	0.724	8	8.37	3.26	300	152.1	13.92
20	0.519	0.813	7	10.6	3.66	350	177.6	14.04
19	0.567	0.912	6	13.3	4.12	400	202.2	15.04
18	0.811	1.02	5	16.7	4.62	450	228	16.05
17	1.04	1.15	4	21.2	5.19	500	253.4	17.95
16	1.31	1.29	3	26.7	5.82	550	278.9	18.85
15	1.65	1.45	2	33.6	6.54	600	304.3	19.69
14	2.08	1.63	1	42.4	7.35	650	329.4	20.47
13	2.63	1.83	1/0	53.5	8.25	750	380	21.99
12	3.31	2.05	2/0	67.4	9.26	800	404.4	22.73
11	4.17	2.3	3/0	85.01	10.4	1000	506.8	25.43
10	5.26	2.59	4/0	107.2	11.68	1250	633.8	28.43

Stripping

Every crimping operation requires that the cable is first stripped without deforming the wires and for a length as indicated below:

Section (sq.mm)	Stripping Tolerance (± mm)
0.5-2.5	0.8
4.0-6.0	1.2
10-120	1.6
150-630	3.2

Assembling

Fit into the connector the cable with a round section for the complete length of the stripped area. Verify that there are not wires out of the connector. If you need to use sectoral cables you must arrange a previous rounded crimping operation of the cable as follow:

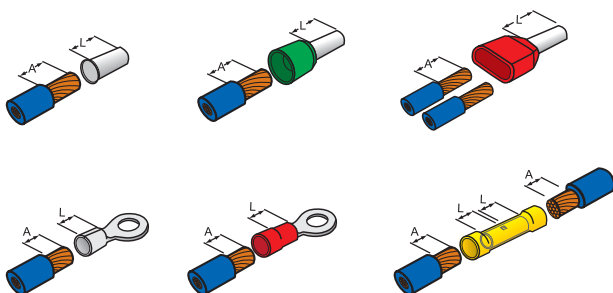

A=L

Using The Crimping Tool to Crimp The Terminals

Make the crimping operation shown as the drawing below:

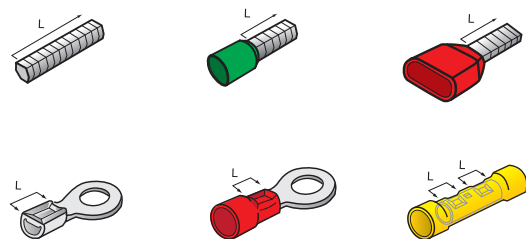

L: Section to be crimped

TOOLS

Due to the high quality of their components, to the ruggedness and simple working, they are particularly suggested for industrial uses. Dies are made of microcasted steel and handles of pressed steel with insulation of plastic material for soft and ergonomic handling. Possibility to adjust the crimping force through the central pin. Equipped with safety device and automatic unclamping to prevent the accidental opening of the dies before the complete execution of the crimping operation, so that uniformity of the connections is always guaranteed.

TOOLS FOR CORD-END TERMINALS

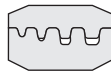

GIT-516E1

- For terminals with wire range: 0.5~4 mm² (22-12 AWG)
- Length: 230 mm (9.06 inch)
- Weight: 600 g (1.32 lbs)



GIT-516E2

- For terminals with wire range: 6~16 mm² (10-6 AWG)
- Length: 230 mm (9.06 inch)
- Weight: 600 g (1.32 lbs)

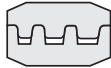

GIT-516E3

- For terminals with wire range: 10~25 mm² (8-4 AWG)
- Length: 230 mm (9.06 inch)
- Weight: 600 g (1.32 lbs)

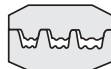

GIT-516E4

- For terminals with wire range: 25~50 mm² (4-1/0 AWG)
- Length: 240 mm (9.45 inch)
- Weight: 600 g (1.32 lbs)



GIT-518

- For terminals with wire range: 50~150 mm² (250/300 AWG)
- Length: 380 mm (14.96 inch)
- Weight: 3,180 g (7.01 lbs)

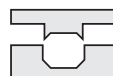

TOOLS

TOOLS FOR TERMINALS



GIT-516T1

- For insulated terminals and connectors
- Applicable range: 0.5~6 mm² (20-10 AWG)
 - 0.5~1.5 mm² (20-16 AWG)
 - 2.5 mm² (14 AWG)
 - 4~6 mm² (12-10 AWG)
- Length: 230 mm (9.06 inch)
- Weight: 600 g (1.32 lbs)



GIT-516T2

- For insulated terminals and connectors
- Applicable range: 10~16 mm² (8-6 AWG)
- Length: 230 mm (9.06 inch)
- Weight: 600 g (1.32 lbs)



GIT-516T3

- For non-insulated terminals
- Applicable range: 1.5~10 mm² (16-8 AWG)
- Length: 230 mm (9.06 inch)
- Weight: 600 g (1.32 lbs)



GIT-516T4

- For non-insulated terminals
- Applicable range: 2.5~16 mm² (14-6 AWG)
- Length: 230 mm (9.06 inch)
- Weight: 600 g (1.32 lbs)

TOOLS FOR C SERIES CLOSED-END CRIMP CONNECTORS



GIT-517C1

- Suitable wire range: 0.5~6 mm² (20-10 AWG)
- Length: 230 mm (9.06 inch)
- Weight: 600 g (1.32 lbs)



GIT-517C5

- Suitable wire range: 4~10 mm² (12-8 AWG)
- Length: 230 mm (9.06 inch)
- Weight: 600 g (1.32 lbs)



Hua Wei Industrial Co., Ltd. is a leading manufacturer of wire and cable management products in the world. Since 1976, Hua Wei has delivered excellence by consistently providing customers with extraordinary quality, first-class customer service, competitive pricing, and timely delivery. With rich experience and expertise, Hua Wei's global reach and presence is unmatched in the industry.

Headquartered in Taichung Taiwan, Hua Wei has expanded its manufacturing operations overseas in China and Thailand that are vertically integrated in design, manufacturing, processing, assembly, and packaging, thus expediting its response to changes in customer needs and market requirements. Moreover, all of Hua Wei manufacturing facilities are certified to ISO/TS16949, ISO9001, and ISO14001, complying with top-level quality systems and minimizing environmental impacts.

Hua Wei offers exceptional service combined with a large selection of products for a variety of applications in electrical, electronics, telecommunications, automotive, shipbuilding, rail, energy, construction, and retailing industries. In addition, to meet industry needs and market requirements, Hua Wei's products have gained UL, CE, CSA, ABS, DNV GL, BV and CQC accreditations and are all compliant with RoHS and REACH regulations.

Building its competitive advantage upon the core goals of innovation, continuous improvement and complete customer satisfaction, Hua Wei always spares no effort in advanced research and development to maintain its leading position and continually invests in its manufacturing operations to ensure customers receive the highest quality products and services.



HUA WEI INDUSTRIAL CO., LTD.

HEADQUARTERS

NO.1, GONGYEQU 26TH RD., NANTUN DIST.,
TAICHUNG CITY, 40850, TAIWAN
TEL: +886-4-23597777
FAX: +886-4-23596705~6
Email: service@hwlok.com
<http://www.hwlok.com>